

# TRIPLE ECCENTRIC BUTTERFLY VALVE, AJ PRIMARY

Metal seated, 3"-110", PN10-PN250/ASME cl.150-ASME cl.1500

985/010-000, 985/020-000,  
985/030-000, 985/040-000,  
985/050-000

Gas Supply

Fire Protection

Water Treatment

Energy

Pulp and Paper

Chemical Processing

Oil and Gas

Marine

Dams, Reservoirs and Hydropower

District Cooling/Heating

Mining

Air Separation

Steel Industry

Triple eccentric butterfly valve, metal seated, available in Wafer, Lug, Flanged short pattern, Flanged long pattern and Buttwelded ends. Different body, disc and seal materials are available to meet specific requirements, ensuring optimal performance. The valves are engineered with an advanced triple-eccentric geometry to ensure precise, low-torque operation even in demanding applications. The metal-to-metal sealing system provides reliable tightness with minimal wear, offering exceptional durability throughout the valve's service life. High-grade materials ensure long-term performance in harsh environments. The valves are designed for true zero-leakage capability and are suitable for bi-directional isolation and control in high-temperature and high-pressure conditions.

## Product description:

AJ Primary triple eccentric butterfly valve for a large variety of service conditions and applications with pressures up to 3771 psi and temperatures from -76 °F to 842 °F.

## Standards:

- Design Standards: API 609 Cat. B, EN 593, ASME B16.34, EN12516
- Face-to-face dimensions according to: API 609, EN 558, ISO 5752, ASME B16.10
- Flange drilling according to: ASME B16.5, ASME B16.47, EN1092-1, ISO 7005
- Buttwelded ends according to: ASME B16.25

## Tests/Approvals:

- Testing: API 598, ISO 5208, EN 12266-1, IEC 60534-4, ISO 15848-2
- API 609 MONOGRAM
- Fire tested to: API 607, ISO 10497
- Compliance with: Pressure Equipment Directive 2014/68/EU, ATEX Directive 2014/34/EU
- SIL assessment: according to IEC 61508 (PFD values up to the SIL 3 range with full and partial stroking test)
- Fugitive Emissions: ISO 15848-1, IOGP S-562 & IOGP S-611, API 641
- For Chinese market: SELO licence for the quality system, TSG for Primary and Cryogenic configurations

## Features:

- Triple eccentric, friction-free sealing geometry minimizing wear on metal sealing surfaces
- Cavity-free body design preventing media entrapment
- Bi-directional or uni-directional tight shut-off capability
- Streamlined flow path engineered for high Cv and reduced pressure loss
- One-piece, high-strength stem for precise disc alignment
- Lamellar or solid metal seal ring configurations for demanding temperature and pressure conditions
- Integral anti-blowout stem system
- Low fugitive-emission packing system
- Intrinsically fire-safe design
- Intrinsically antistatic construction ensuring safe operation in potentially explosive atmospheres
- Special executions include NACE-compliant materials, CRA overlay, FBE internal coating, quick-acting and high-cycle configurations, and optional stem extensions

## Accessories:

Gearbox, pneumatic, hydraulic and electric actuators, position indicators, solenoid valves, positioners



Wafer  
STV 985/010-000

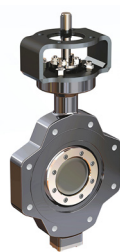

Lug  
STV 985/020-000

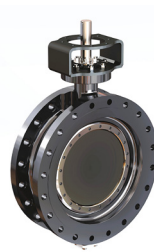

Flanged short pattern  
STV 985/030-000

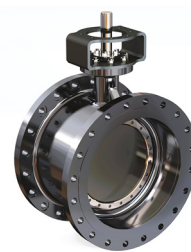

Flanged long pattern  
STV 985/040-000



Buttwelded ends  
STV 985/050-000



SIL

CE



The designs, materials and specifications shown are subject to change without notice. This is due to the continuous development of our product programme.

# TRIPLE ECCENTRIC BUTTERFLY VALVE, AJ PRIMARY

Metal seated, 3"-110", PN10-PN250/ASME cl.150-ASME cl.1500

985/010-000, 985/020-000,  
985/030-000, 985/040-000,  
985/050-000

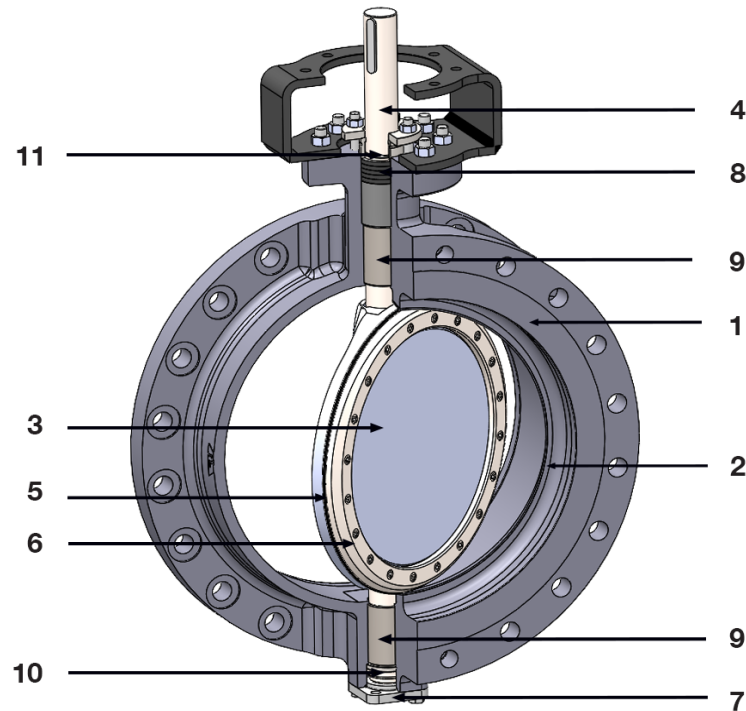

## Components:

1. Body	Carbon steel Stainless steel Alloy steel Duplex / Super Duplex Ni-Aluminium Bronze Nickel alloy (Inconel 625/718) Super austenitic stainless steel Titanium	6. Disc flange (Retaining ring)	see body materials
2. Seat	Hard facing: ErCoCr-E, ErNiCrMo-3	7. Bottom cover	see body materials
3. Disc	see body materials	8. Packing	Graphite with reinforcement (Stainless steel or Inconel) or PTFE
4. Shaft	Martensitic stainless steel Austenitic stainless steel Duplex / Super Duplex Nickel alloy (Inconel 718) Ni-Cu alloy Super austenitic stainless steel Titanium	9. Radial bearings	Stainless steel Super Duplex Hastelloy Titanium Ni-Cu alloy Cobalt Alloy
5. Seal ring (lamellar)	Duplex + Graphite or PTFE Super Duplex + Graphite or PTFE Hastelloy + Graphite or PTFE Titanium + Graphite or PTFE	10. Axial bearing	see radial bearings
5. Seal ring (solid)	Stainless steel Super Duplex Nickel alloy (Inconel 625/718)	11. Anti-blowout gland	Stainless steel Ni-Cu alloy Super Duplex Titanium