

**AVK** TRIPLE ECCENTRIC BUTTERFLY VALVES

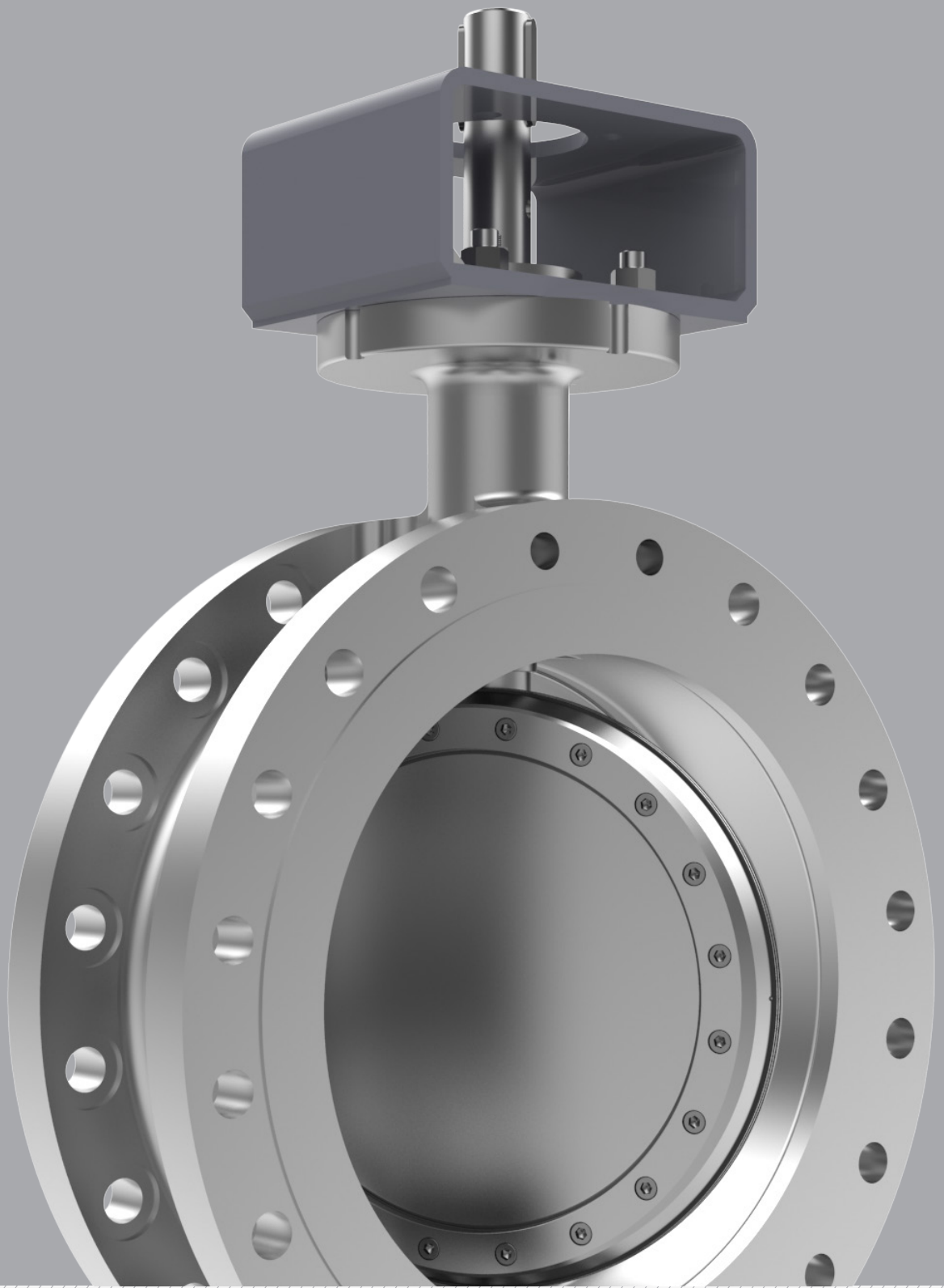

**TRIPLE ECCENTRIC BUTTERFLY VALVES  
AJ & TJ SERIES**



# ZERO LEAKAGE, RELIABLE AND DURABLE



# METAL-TO-METAL SHUT OFF FOR DEMANDING APPLICATIONS



The AJ and TJ Series are metal-seated triple eccentric butterfly valves designed for tight shut-off in high-pressure and extreme temperature services. The valve geometry eliminates seat rubbing during operation, significantly reducing wear and ensuring consistent performance over the full service life.

The AJ and TJ Series Triple Eccentric Butterfly Valves represent a proven solution for applications requiring tight shut-off, extreme temperature resistance, and minimal operating torque. Their advanced triple offset design ensures friction-free operation and reliable sealing under extreme service conditions.

The valves are ideal for a wide variety of industrial processes and applications, including Oil & Gas, LNG, and petrochemical - both onshore and offshore – as well as chemical and power generation plants.

Designed for demanding service conditions, they can be applied in isolation, on/off and control service, as well as in high-cycling, quick-acting, and safety critical functions such as Emergency Shutdown (ESD) and High Integrity Pressure Protection Systems (HIPPS).

The robust triple offset design ensures reliable, tight shut-off performance across a broad temperature range—from low and cryogenic service to high-temperature applications—while maintaining low operating torque.

They are available in pressure ratings up to ASME Class 1500 (PN250), making them a reliable solution for critical and severe process conditions.

# OPERATING PRINCIPLE

# TRIPLE ECCENTRIC

# VALVES

AJ and TJ are quarter-turn triple eccentric butterfly valves designed to eliminate friction throughout the full 90° rotation. Their asymmetric geometry incorporates three distinct offsets combined with a metal-to-metal sealing system, ensuring tight shut-off and extended service life.

## Offset 1

The valve shaft is offset from the seating surface to maintain continuous contact geometry between the seal ring and the seat.

## Offset 2

The shaft is positioned eccentrically relative to the pipe centerline, allowing the seal ring to shift from the seat during rotation.

## Offset 3

The seat is manufactured with a conical geometry, with the cone axis inclined relative to the pipe centerline. This design prevents any rubbing between the sealing surfaces, ensuring friction-free operation.

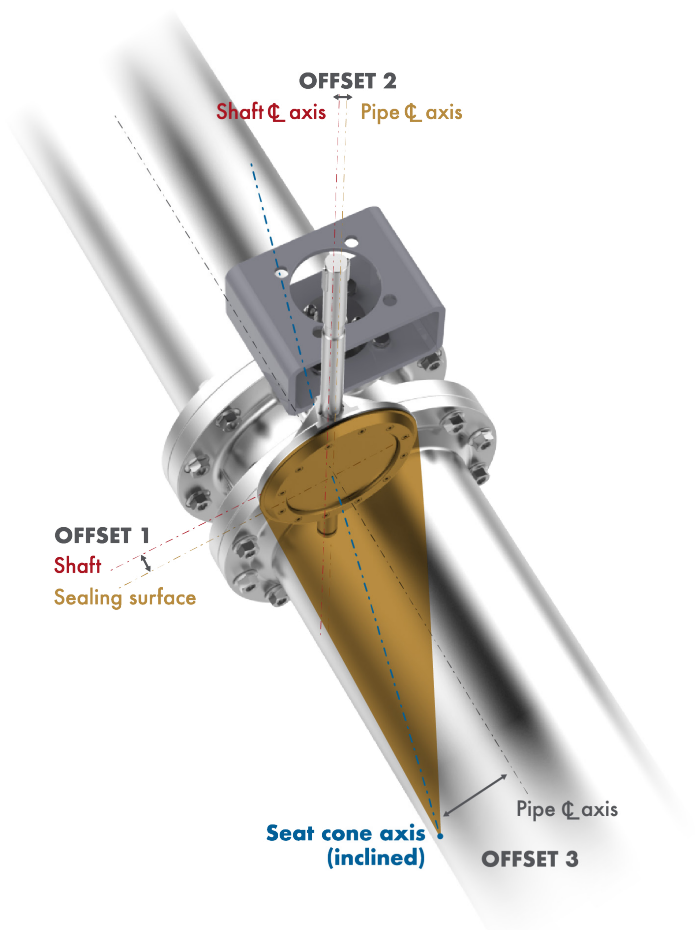

# SEALING BENEFITS

An advanced sealing concept ensures reliable shutoff under extreme conditions.

## Sealing Concept

The seal ring, located in the disc, flexes and radially compresses against the seat, allowing for uniform torque distribution. This factor, together with the conical shape of both sealing components make AJ and TJ Series torque-seated valves, with low torque requirements, and with an excellent tight shutoff performance.

The Zero Leakage tightness (\*) under the most severe conditions is attained regardless of shut-off pressure direction. Furthermore, the two sealing elements are of total metallic construction, permitting the use of the Triple Eccentric Valves on a wide spectrum of pressures and temperatures.

The elimination of rubbing considerably extends the overall life of sealing components, ensuring therefore low maintenance activity on site, and ease of operation.

(\*) Zero leakage tested in accordance with API 598, ISO 5208, EN 12266-1, API 6D

**Before Sealing Contact**

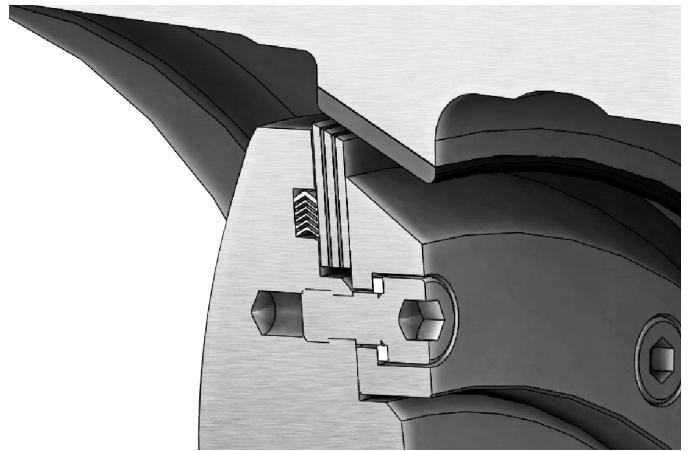

**After Sealing Contact**

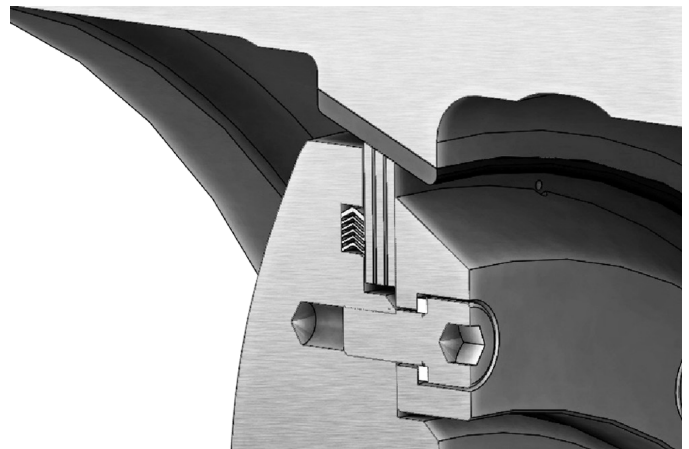

# BENEFITS FOR RELIABLE PERFORMANCE

Designed for performance where it matters most, the AJ Series 985 and TJ Series 986 offer a combination of compact design, operational efficiency, and long service life, all produced under the highest quality standards.

- **The non-rubbing design eliminates friction** and prevents wear of the sealing elements throughout the valve's service life. As a result, the valves are essentially maintenance-free, requiring minimal spare parts and allowing for easy servicing.
- Through torque seating, non-rubbing rotation, and an asymmetric design with a preferred sealing direction, the valves deliver **long-term operating reliability**. This design ensures **consistent tight shut-off** while inherently reducing the risk of systematic failures.
- Designed to meet on-site requirements for controlled and predictable torque, the valves maintain a **low and constant torque demand** over its service life. This allows the use of low-size actuators and ensures easy operation of manual valves.
- The triple offset geometry results in a highly compact valve design, delivering **significant space and weight savings**—key advantages in industrial installations, particularly within the Oil & Gas sector.



# AJ SERIES 985 CONFIGURATIONS

The AJ Series 985 is available in different configurations to suit a wide variety of service requirements. Multiple body designs, together with a comprehensive selection of body, disc and seal ring materials, allow the valve to be precisely configured for specific process conditions.

## Design configurations

- Primary: From -76 to +842°F
- Cryogenic: Down to -320.8°F
- High Temperature: Up to +1472°F
- Steam jacketed
- Subsea

AJ Series 985	
Nominal Diameter	3" to 112"
Working Pressure	up to 3771 psi
Body Construction	Wafer, Lug, Flanged short pattern, Flanged long pattern, Buttwelded ends
Flange Connection	EN PN10-PN250 ASME cl.150-ASME cl.1500
Body Materials	Carbon steel, Stainless steel, Alloy steel, Duplex, Super Duplex, Ni-Aluminium Bronze, Nickel alloy (Inconel 625/718), Super austenitic stainless steel, Titanium
Design	ASME B16.34, API 609, EN 593, EN 12516
Face-to-Face	ISO 5752, API 609, EN 558, ASME B16.10
Flange Drilling	ASME B16.5, ASME B16.47, EN 1092-1, ISO 7005
Buttwelded ends	ASME B16.25

## Tests/Approvals

- Testing: API 598, ISO 5208, EN 12266-1, IEC 60534-4, ISO 15848-2
- API 609 MONOGRAM
- Fire tested to: API 607, ISO 10497
- Fugitive Emissions: ISO 15848-1, IOGP S-562 & IOGP S-611, API 641
- Cryogenic prototype testing: ISO 28921-2
- Compliance with: Pressure Equipment Directive 2014/68/EU, ATEX Directive 2014/34/EU
- SIL assessment: according to IEC 61508 (PFD values up to the SIL 3 range with full and partial stroking test)
- For Chinese market: SEL0 licence for the quality system, TSG for Primary and Cryogenic configurations

## Design features

- Triple eccentric, friction-free sealing geometry minimizing wear on metal sealing surfaces
- Bi-directional or uni-directional tight shut-off capability
- Low fugitive-emission packing system
- Integral anti-blowout stem system
- Intrinsically fire-safe design
- Intrinsically antistatic construction ensuring safe operation in potentially explosive atmospheres
- One-piece, high-strength stem for precise disc alignment
- Lamellar or solid metal seal ring configurations for demanding temperature and pressure conditions
- Streamlined flow design for high Cv and reduced pressure loss
- Cavity-free body design preventing media entrapment
- Special executions include NACE-compliant materials, CRA overlay, FBE internal coating, quick-acting and high-cycle operations, and optional stem extensions

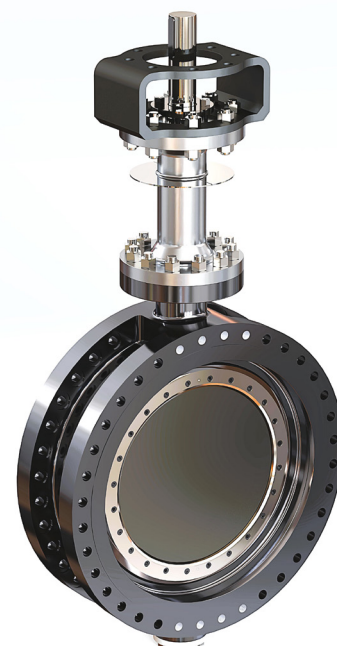

# TJ SERIES 986 CONFIGURATION

The TJ Series 986 features a top-entry design that enables easy maintenance without removing the valve body from the pipeline – minimizing downtime and simplifying service for cryogenic applications.

## Design configurations

- Cryogenic: Down to -321°F

TJ Series 986	
Nominal Diameter	6" to 96"
Working Pressure	up to 3771 psi
Body Construction	Buttwelded ends, Flanged
Flange Connection	EN PN10-PN250 ASME cl.150-ASME cl.1500
Body Materials	Stainless steel
Design	ASME B16.34, API 609, EN 593, EN 12516
Face-to-Face	ISO 5752, API 609, EN 558, ASME B16.10
Flange Drilling	ASME B16.5, ASME B16.47, EN 1092-1, ISO 7005
Buttwelded ends	ASME B16.25

## Tests/Approvals

- Testing: API 598, ISO 5208, EN 12266-1, IEC 60534-4, ISO 15848-2
- API 609 MONOGRAM
- Fire tested to: API 607, ISO 10497
- Fugitive Emissions: ISO 15848-1, IOGP S-562 & IOGP S-611, API 641
- Cryogenic prototype testing: ISO 28921-2
- Compliance with: Pressure Equipment Directive 2014/68/EU, ATEX Directive 2014/34/EU
- SIL assessment: according to IEC 61508 (PFD values up to the SIL 3 range with full and partial stroking test)
- For Chinese market: SELO licence for the quality system, TSG for Primary and Cryogenic configurations

## Design features

- Triple eccentric, friction-free sealing geometry minimizing wear on metal sealing surfaces
- Top entry design, allowing easy maintenance without removal of the installed valve from the pipe
- Bi-directional or uni-directional tight shut-off capability
- Low fugitive-emission packing system
- Integral anti-blowout stem system
- Intrinsically fire-safe design
- Intrinsically antistatic construction ensuring safe operation in potentially explosive atmospheres
- One-piece, high-strength stem for precise disc alignment
- Solid metal seal ring configurations for demanding temperature and pressure conditions
- Streamlined flow design for high Cv and reduced pressure loss
- Cavity-free body design preventing media entrapment



# RELIABLE SERVICE AT CRYOGENIC TEMPERATURES

Cryogenic processes place critical demands on valve performance, reliability, and safety.

Cryogenic applications involve the handling, control, and storage of liquefied gases at extremely low temperatures down to -321 °F. At these conditions, materials, sealing systems, and valve performance are pushed to their limits, making reliability and safety critical.

Such applications are found across LNG, industrial gases, and energy plants, where fluids must be managed safely and efficiently.

The **AJ Cryogenic and TJ Cryogenic Triple Eccentric Butterfly Valves** ensure tightness performance in accordance with main international standards, a strong reduction in

the risk of fugitive emissions, and long-term durability in the most challenging cryogenic environments.

The valves undergo cryogenic testing in AVK Piacenza's advanced cryogenic facility, featuring two testing bunkers designed for pressure up to 480 bar, and able to accommodate testing of valves up to 96 inches.

## Typical applications

- LNG liquefaction plants
- LNG storage tanks
- LNG loading and unloading terminals
- Regasification facilities
- Industrial gas processing and storage



# THE RIGHT CHOICE FOR DEMANDING INDUSTRIAL APPLICATIONS

## Typical applications

- Oil & Gas
- Energy
- Chemical Processing
- Marine
- Mining
- Steel Industry
- Pulp & Paper
- Water Treatment
- District Cooling & Heating

The AJ Series 985 and TJ Series 986 are engineered for a wide range of demanding industrial process applications where extreme temperatures and high pressures are critical. Proven in plants worldwide, the triple eccentric valve solutions are backed by a dedicated team of experts who work closely with you to deliver the optimal configuration for your specific process requirements.



Crude Oil Tank Farms, Egypt

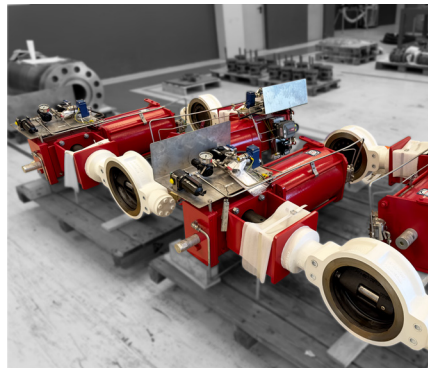

Underground Gas Storage, Turkey



Refinery H2 Plant & Sulphur Rec. Plant, Mexico

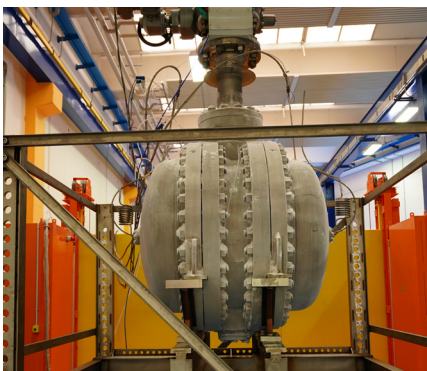

Steam Cracking Blow Down (Ground-level Smokeless Torch), Italy

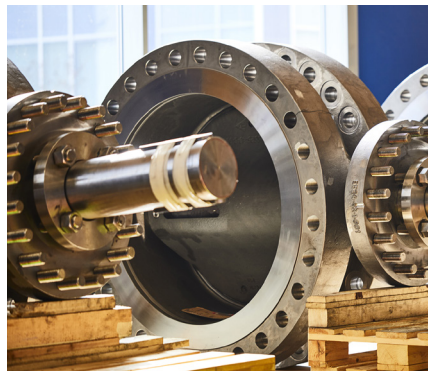

PTA Production Plant, China

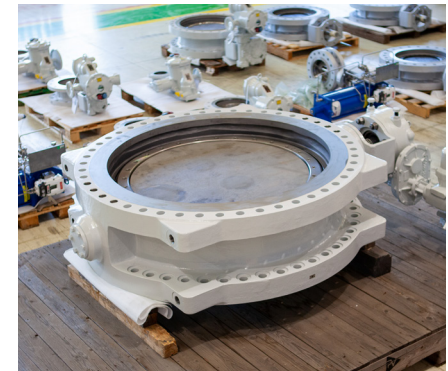

Ammonia Production Plant, USA

# MANUFACTURING EXCELLENCE

The AJ and TJ Triple Eccentric Valves are manufactured at AVK Piacenza, where innovation, advanced technology, and manufacturing excellence converge to deliver outstanding performance and reliability.

The valves are manufactured at AVK Piacenza, a center of innovation driven by operational excellence and a strong commitment to Research & Development. Operational excellence is built on three pillars: lean manufacturing, total quality management, and integrated supply chain management.

AVK's supply chain is supported by a robust network of qualified suppliers, selected and monitored through strict approval processes, KPIs, and quality audits.

The Piacenza plant spans 23,000 m<sup>2</sup>, with 8,000 m<sup>2</sup> dedicated to production and equipped with CNC horizontal & vertical lathes up to 3000mm rotating table, CNC machining centers with multi-pallet system, welding robot system, CNC testing machines with integrated torque measuring system, cryogenic testing facility up to 96" and up to 480 bar, 3D co-ordinates measuring machines and high pressure gas test bunkers up to 15,000 psi, enabling full in-house manufacturing of the complete valve range.

Management systems certificates cover:

- Quality Management System  
UNI EN ISO 9001
- Environmental Management System  
UNI EN ISO 14001
- Health and Safety Management System  
UNI ISO 45001
- PED - Total Quality Module H 2014/68/EU



