



AVK KNIFE GATE VALVE, PN10

702/20-103

Rising stem and handwheel, replaceable top packing gland, DN50-600

AVK lug/wafer knife gate valves are bi-directional with full and plane bore. The protected sealings and high quality materials bring about a great performance and a long service life. AVK knife gate valves are available with lever, non-rising stem and handwheel, rising stem and handwheel, pneumatic actuator, ISO top flange for actuator or complete with electric actuator.

Product description:

Knife gate valve with rising stem and handwheel for wastewater treatment 0°C to +80°C

Standards:

- Face-to-face dimension according to DIN/EN 558-1, series 20 (K1), up to and incl. DN 350
- Standard flange drilling to EN1092-2 (ISO 7005-2), PN10/16

Features:

- Replaceable top packing gland enables sealing replacement without disassembly of the valve
- The valve is self cleaning as particles will be pushed off the gate when opening the valve. For extra protection of the packing gland a scraper is available as an optional extra.
- Bi-directional, can be installed independent of the flow direction
- Full bore with no reduction of the flow
- Plane bottom prevents sediment from being accumulated
- No cavity in the body and thus no risk of clogging
- U-shaped one-piece NBR sealing between the body parts makes up for tolerances in coating and casting. It is reinforced with a steel insert to protect it from being damaged during operation.
- Encaged stem with yokes prepared for mounting of micro switches and inductive sensors
- Stem and gate connection is secured with self-locking nuts
- Supports integrated in the body casting protect the gate from deflecting under pressure
- Body of ductile iron with 100-150 µm UV resistant polyester coating, RAL 5017. Optionally of acid-resistant stainless steel or duplex
- Yokes of carbon steel with coating 100-150 µm of plascoat PPA 571 Aqua
- Gate, stem, bolts and nuts of acid-resistant stainless steel
- Washers under the bolts protect the coating
- Slim design and low weight
- Approved according to the 97/23/CE European Pressure Equipment Directive
- Approved according to the 94/9/94EC, ATEX Directive
- Available in larger dimensions
- Optionally in higher PN class



Expect ... **AVR**

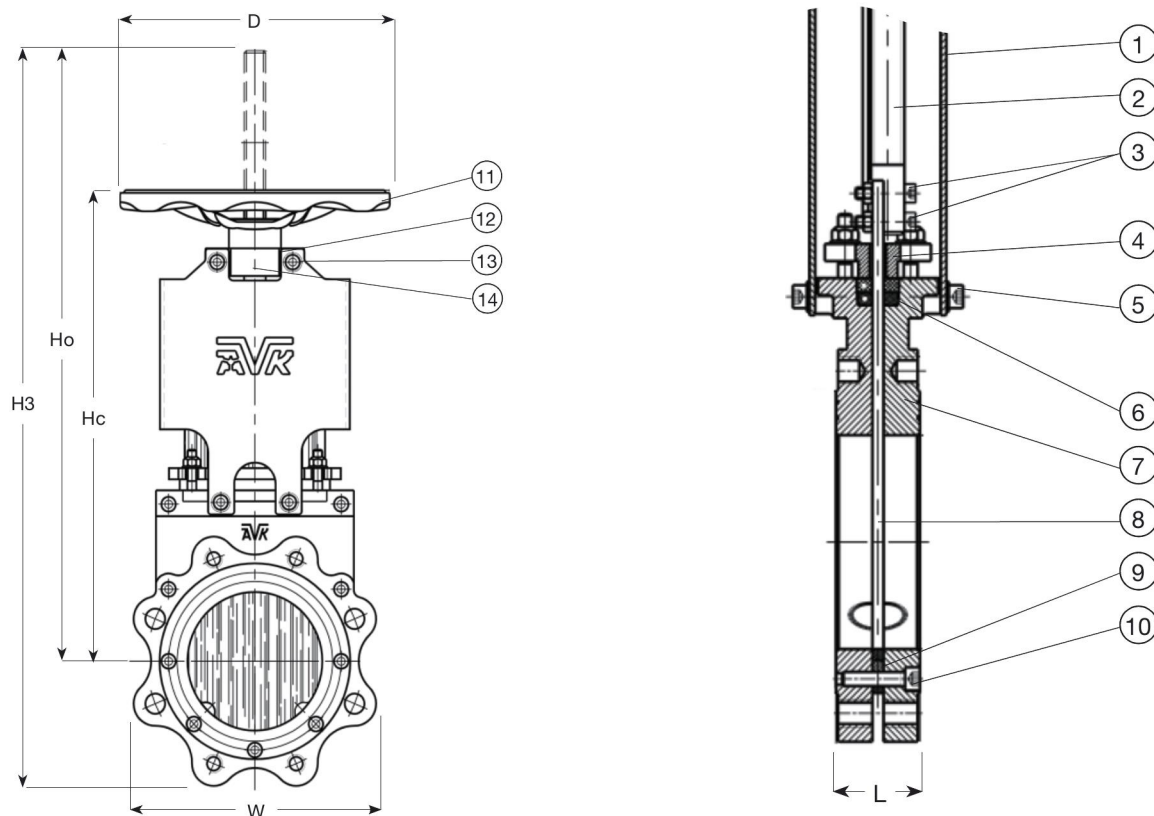

Component list:

1. Plate	Carbon steel	8. Gate	Stainless steel 316
2. Stem	Stainless steel 316	9. U-shaped seal	Steel / NBR
3. Bolt	Stainless steel A4	10. Bolt	Stainless steel A4
4. Top packing gland	Ductile iron GJS-400-15 (GGG-40)	11. Handwheel	Steel
5. Bolt	Stainless steel A4	12. Washer	Stainless steel A4
6. Packing	NBR + PTFE	13. Bolt	Stainless steel A4
7. Body	Ductile iron GJS-400-15 (GGG-40)	14. Bearing	Carbon steel

Components may be substituted with equivalent or higher class materials without prior notification.

Reference nos. and dimensions:

AVK ref. no.	DN	Flange	D	L	H3	HC	HO	W	Test pressure	Working Pressure	Theoretical weight/kg
	mm	drilling	mm	mm	mm	mm	mm	mm	bar	bar	
702-0050-10-0000133	50	PN10	175	43	424	292	359	130	15	10	6.5
702-0065-10-0000133	65	PN10	175	46	471	317	399	143	15	10	8.0
702-0080-10-0000135	80	PN10	225	46	536	361	444	183	15	10	12
702-0100-10-0000144	100	PN10	225	52	601	396	499	202	15	10	14
702-0125-10-0000146	125	PN10	225	56	675	432	560	229	15	10	19
702-0150-10-0000147	150	PN10	300	56	809	523	674	270	15	10	28
702-0200-10-0000026	200	PN10	300	60	989	623	824	326	15	10	44
702-0250-10-0000026	250	PN10	300	68	1179	729	980	395	15	10	62
702-0300-10-0000023	300	PN10	400	78	1386	858	1160	451	15	10	85
702-0350-10-0000026	350	PN10	400	78	1560	951	1303	518	9	6	124
702-0400-10-0000016	400	PN10	400	90	1749	1059	1461	576	9	6	159
702-0450-10-0000022	450	PN10	500	90	1977	1206	1664	560	6	4	227
702-0500-10-0000015	500	PN10	500	95	2139	1308	1816	698	6	4	278
702-0600-10-0000015	600	PN10	500	105	2518	1497	2105	817	6	4	382