

FPCV - Flanged Poppet Check Valve

Description

The FPCV check valve, with flanged ends, for use in the most demanding corrosive and toxic applications. The product is available for both standard DIN PN 10/16 and ANSI 150.



Product features

- Design suitable for both horizontal and vertical installation
- Flanged connection for installations not compatible with the wafer installation
- Guided spring and poppet - secure from misalignment
- Ideal design for low pressure duties
- Full bore design provides maximum flow with minimum pressure drop
- Hastelloy C276 spring as standard, other materials available
- Poppet lift pressure 14 mbar
- Standard face to face dimensions
- Customized connections available

Material specification

Item	Qty	Description	Materials	Specification	DIN equivalent material
1	1	Valve body	Carbon steel / PFA	ASTM A216 Gr. WCB / PFA	1.0619 / PFA
2	1	Spring	Hastelloy® C276	ASTM B574 Gr UNS N10276	2.4819
3	1	Poppet	Glass filled PTFE	BS6564 UA1/1	-
4	4 / 6	Nut	Stainless steel	ASTM F594 Gr. 304	1.4301
5	4 / 6	Stud	Stainless steel	BS970 Pt 1 Gr 303S42	1.4305
6	1	Valve Inlet	Carbon steel / PFA	ASTM A216 Gr. WCB / PFA	1.0619 / PFA
		Paint finish	75 µm, RAL 5021	Epoxy coating	-
		PFA lining	ASTM D 3307		

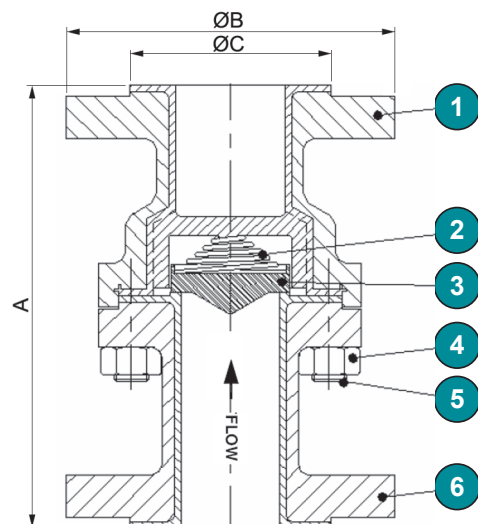

Dimensions

Nominal size		Face to face	Flange diameter	Raised face	Weight
ANSI 150 Piping systems					
Inch	mm	A	ØB	ØC	kg
1	25	152	110	51	3.9
1½	40	178	125	73	7.1
2	50	203	150	92	9.5
3	80	241	190	127	17.1
4	100	292	230	157	27.7
DIN PN 10/16 Piping systems					
Inches	mm	A	ØB	ØC	kg
1	25	160	115	68	4
1½	40	200	150	88	7
2	50	230	165	102	10
3	80	310	200	138	20
4	100	350	220	158	30

Pressure / Temperature Diagram

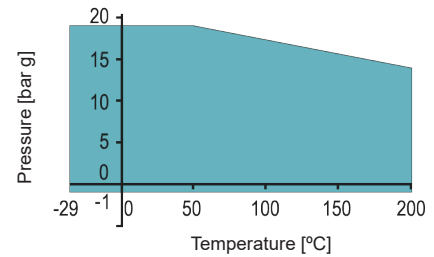

Options

Component	Description
Body	Stainless steel
Lining	Conductive PFA
Length	Special face to face dimensions
Spring	Alternative pressure ratings
	PTFE encapsulated
	Alternative spring materials
	Without spring (floating poppet)

Type code

FPCV	080	.	3	3	.	3HT	.	0TG	-	S
①	②		③	④		⑤		⑥		⑦

①	Type	FPCV	Flanged Poppet Check Valve
②	Nominal diameter	025 - 100	mm
③	Working pressure	3	16 bar
④	Rating	3	PN 10/16
		A	ANSI Class 150 others on request
⑤	Body	3HT	Carbon steel / PFA
		4MT	Stainless steel / PFA
⑥	Poppet	0TG	Glass filled PTFE
⑦	Spring		without spring (floating poppet)
		S	Hastelloy C276