

Description

The rack and pinion pneumatic actuator IA Motion combines innovative design features with the latest technology, materials and protection coatings available, resulting in one of the highest grade pneumatic actuators on the market.

Product features

- Function **IA...D** double acting
IA...S single acting
- Nominal torque 131 ÷ 91611 Lb-In
(double acting at 6 bar air supply)
- Supply pressure 40 ÷ 116 psi (IA1000D 40 ÷ 110 psi)
- Supply fluids Filtered air or neutral gas
- Working temperature -40°F ÷ 176°F
- Connection Mounting face for valves according to EN ISO 5211,
for solenoid valves and accessories to VDI/VDE 3845 (NAMUR)
- Lubrication Factory lubricated for the life of actuator under normal working conditions
- ATEX Actuator IP68, standard in compliance with ATEX 94/9/EC

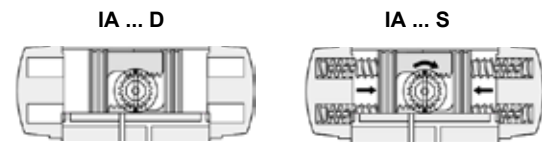

Design properties

- Compact design with identical body and end caps for double acting and spring return types, allowing field conversion by adding or removing spring cartridges.
- Body made of extruded aluminium with internal and external ALODUR® corrosion protection, with honed cylinder surface for a higher cycle life and lower coefficient of friction.
- Symmetric rack and pinion design for high-cycle life and fast operation. Reverse rotation can be accomplished by inverting the pistons.
- Two independent external travel stop adjustments, enabling an easy and precise adjustment of -5°+15° / 75°+95°, in order to get a precise valve positioning.
- One-piece blow-out proof, electroless nickel-plated drive shaft with bearing guided one-piece pinion for improved safety and max. cycle life.
- Fully machined piston teeth for accurate low backlash rack and pinion engagement and maximum efficiency.
- Pistons standard anodised for higher life.
- Multifunction position indicator, adaptable to all kinds of limit and proximity switches.
- Preloaded spring cartridges with coated springs for simple versatile range and corrosion resistance. Spring return actuator can be disassembled without danger on field.
- High quality bearings and seals for low friction, high cycle life and a wide operating temperature range.
- End caps, anodized and Polyester® coated (RAL 5021).
- All used screws in stainless steel for life time corrosion resistance.
- Full compliance to the latest specifications: EN ISO 5211, VDI/VDE 3845, NAMUR and ATEX (Directive 94/9/CE).
- Every single actuator is tested and provided with a unique serial number for traceability.

Your benefits

- High quality actuator designed for high-cycle life.
- Multiple mounting circles and shafts to fit most quarter turn valves.
- Easy conversion from double to single acting and vice versa.
- Lower inventory with greater flexibility.
- Position indicator with graduated ring indicating accurate angle.
- Two external travel stop adjustments for easy valvepositioning $-5^{\circ} \pm 15^{\circ} / 75^{\circ} \pm 95^{\circ}$.
- Extensive size range to fit the requested torque at lowest costs.
- Full compliance to latest worldwide standards.

Materials

Body	Extruded aluminium EN AW-6063, ALODUR® corrosion protected (IA045-750), anodized and polyurethane coated (IA800-1000)
End caps	EN AC-46000, anodized and Polyester® coated (RAL 5021)
Pistons	EN AC-46000, anodized
Springs	SiCr spring alloy steel, Epoxy coated
Shaft	C22, nickel plated
Position indicator	PA66 + 30%GF + carbon black

Function

IA...D double acting actuator

Air supplied to port ② moves pistons toward endposition.
(→ 90° counterclockwise rotation)

Air supplied to port ④ moves pistons toward center position.
(→ 90° clockwise rotation)

IA...S single acting actuator

Air supplied to port ② moves pistons toward endposition, compressing springs
(→ 90° counterclockwise rotation)

Air failure allows springs to move pistons toward center position
(→ 90° clockwise rotation)

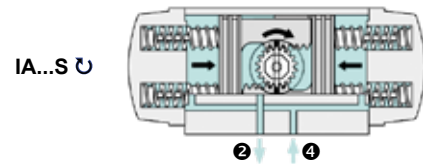
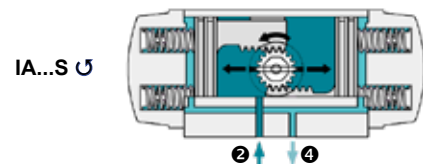
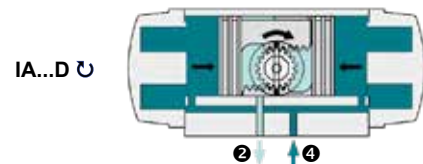
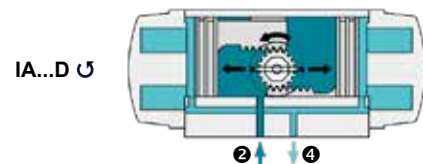
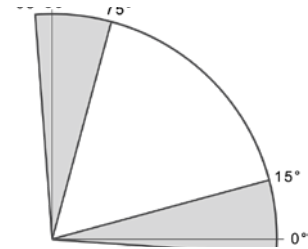

Type code

IA200 D . F05 - F07 14

① ② ③ ④

① Actuator size	IA045 - IA1000	
② Function	D	Double acting
	S12	Single acting + number of springs
③ Mounting face for valve	F03 - F30	According to EN ISO5211
④ Shaft connection	[mm]	Dimension of shaft connection

Available options:

- 5 different external coatings.
- Stainless steel AISI 303, 430 or 316 drive shaft.
- High and low temperature versions.
- 0 + 90° adjustable travel stop.
- Cost efficient lock out capability.
- Other drive shaft connections.
- Rotation 120° and 180° and intermediate such as 135°.
- 3 position actuators.
- Stainless steel actuators.

Please contact our technical department for more information about these options.

0 + 90° adjustable travel stop

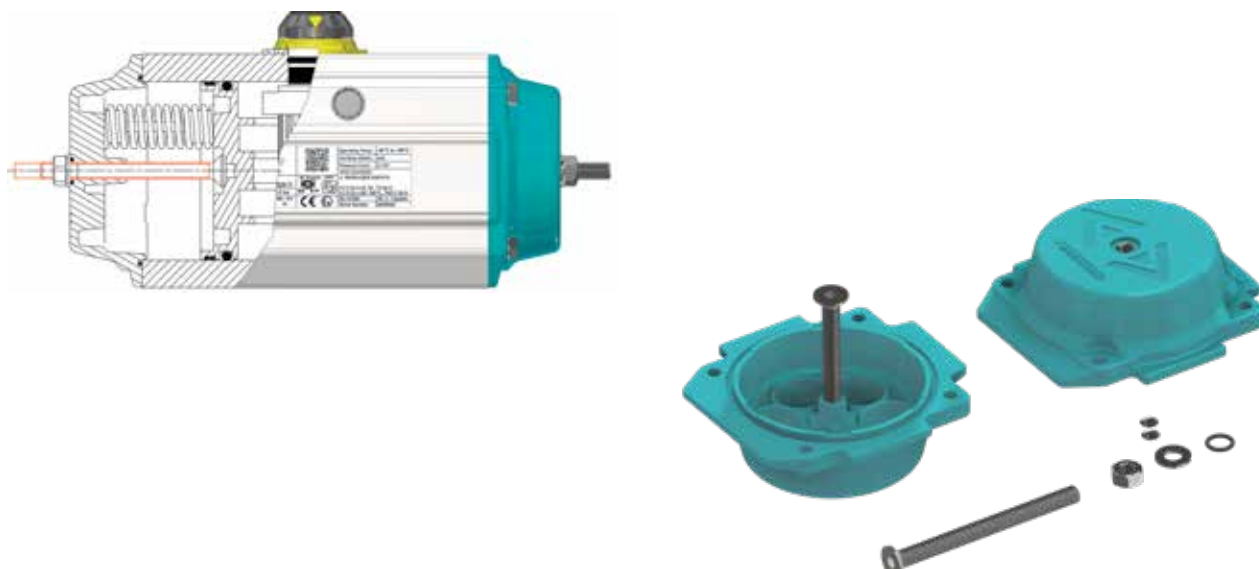

Torques [Nm]

IA...D - Double acting actuators

	Pneumatical torque at air supply of					
	50 psi	60 psi	70 psi	90 psi	100 psi	116 psi
IA 045 D	72,9	87,4	102	131	146	169
IA 050 D	101	122	142	183	203	235
IA 100 D	179	215	251	322	358	415
IA 200 D	355	426	497	639	710	824
IA 250 D	559	670	782	1005	1170	1296
IA 300 D	811	974	1136	1461	1623	1883
IA 350 D	1312	1574	1836	2361	2623	3043
IA 400 D	1691	2029	2367	3043	3381	3922
IA 450 D	2654	3185	3716	4777	5308	6157
IA 500 D	3462	4155	4847	6232	6925	8032
IA 550 D	4674	5609	6544	8413	9348	10844
IA 600 D	6492	7790	9088	11685	12984	15061
IA 650 D	10906	13087	15269	19631	21812	25302
IA 700 D	15829	18995	22161	28493	31659	36724
IA 750 D	21910	26291	30674	39438	43820	50831
IA 800 D	27493	32991	38490	49487	54985	63783
IA 1000 D	50895	61074	71253	91611	101790	-

IA...D

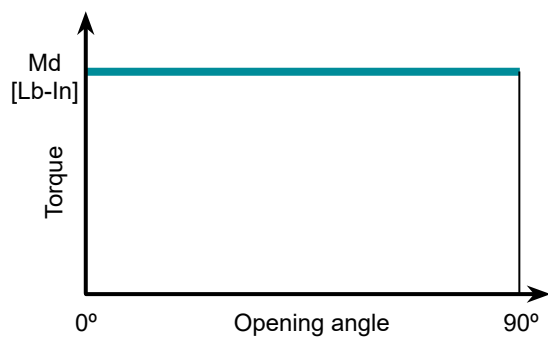

IA...S

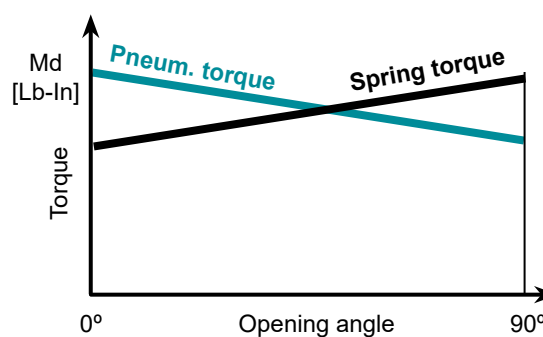

1) IA045 S33, IA050 - IA550. S12 = Standard version of InterApp. Other number of springs on request

Torques [Nm]

IA...S - Single acting actuators

		Pneumatical torque at air supply of												Spring [Lb-In]	
		40 psi		60 psi		70 psi		90 psi		100 psi		116 psi		90°	0°
		0°	90°	0°	90°	0°	90°	0°	90°	0°	90°	0°	90°		
IA045	S 12	35,3	15,8											42,5	23
	S 22			56,5	30,8	71	45,5							56,6	31
	S 33							86,9	46,2	101	60,8	125	84,1	85	44,3
IA050	S2	46,1	24,7	86,6	65	107	85,6	147	126	168	146			58,5	35,1
	S4			75	46,3	95,2	67	136	107	156	127	189	160	75	46,8
	S6					83,5	47,9	124	88,4	144	109	177	141	94,1	58,5
	S8							112,4	69,5	133	90	165	122	113	70,2
IA100	S 06	84,2	53,5	156	125	192	161	263	232	299	268			89,6	58,9
	S 08			136	95,2	172	131	243	203	279	238	337	296	119	78,8
	S 10			ja		152	101	224	173	260	209	317	266	149	98,2
	S 12 ¹⁾									240	179	297	236	179	118
IA200	S 06	167	100	309	242	380	313	522	455	593	526			164	117
	S 08			269	181	340	252	483	394	554	465	667	579	245	157
	S 10			ja		301	191	443	333	514	404	528	517	306	196
	S 12 ¹⁾									475	342	589	456	368	235
IA250	S 06	252	140	476	364	587	475	811	699	922	810			307	195
	S 08			411	261	522	373	746	597	858	708	1036	887	409	260
	S 10					457	271	681	494	793	606	971	785	511	325
	S 12 ¹⁾									728	504	906	683	613	389
IA300	S 06	380	231	705	555	867	718	1192	1042	1354	1205			418	269
	S 08			615	416	777	578	1102	903	1264	1065	1524	1325	558	359
	S 10					688	439	1012	763	1174	926	1434	1185	679	449
	S 12 ¹⁾									1085	786	1344	1046	837	538
IA350	S 06	614	354	1139	878	1401	1141	1926	1665	2188	1928			696	435
	S 08			993	646	1256	909	1780	1433	2043	1696	2463	2115	928	581
	S 10					1111	677	1635	1201	1898	1464	2317	1883	1160	726
	S 12 ¹⁾									1753	1232	2172	1652	1392	871
IA400	S 06	795	477	1471	1154	1809	1492	2485	2168	2823	2506			875	558
	S 08			1285	862	1623	1200	2299	1876	2637	2214	3178	2755	1167	744
	S 10					1437	908	2113	1584	2452	1923	2993	2464	1459	930
	S 12 ¹⁾									2266	1631	2607	2172	1750	1116
IA450	S 06	1248	755	2310	1816	2841	2347	3902	3409	4433	3939			1369	875
	S 08			2018	1360	2549	1891	3611	2952	4142	3483	4991	4333	1825	1166
	S 10					2258	1435	3319	2496	3850	3027	4699	3876	2281	1458
	S 12 ¹⁾									3558	2571	4408	3420	2737	1750
IA500	S 06	1578	1006	2963	2391	3655	3083	5040	4468	5733	5161			1784	1192
	S 08			2566	1803	3258	2495	4643	3380	5336	4573	6444	5681	2352	1589
	S 10					2861	1907	4246	3292	4938	3985	6046	5093	2940	1988
	S 12 ¹⁾									4541	3397	5649	4505	3528	2383
IA550	S 06	2060	1225	3930	3094	4865	4029							2515	1679
	S 08			3370	2256	4305	3191	6175	5060	7109	5995			3353	2239
	S 10					3745	2353	5615	4222	6550	5157	8045	6653	4191	2798
	S 12 ¹⁾									5990	4319	7486	5814	5029	3358
IA600	S 06	2935	1849	5532	4445	6830	5744							3345	2258
	S 08			4779	3330	6078	4629	8674	7225	9973	8524			4480	3011
	S 10					5325	3514	7922	6110	9220	7409	11297	9486	5575	3763
	S 12									8467	6294	10545	8371	6690	4516
IA650	S 06	4897	3190	9260	7553	11441	9734							5534	3828
	S 08			7984	5708	10165	7889	14527	12252	16709	14433			7379	5104
	S 10					8889	6045	13251	10407	15433	12588	18923	16078	9224	6380
	S 12									14157	10743	17647	14233	11069	7656
IA700	S 06	6870	4158	13202	10490	16368	13656							8505	5793
	S 08			11271	7655	14437	10821	20769	17152	23934	20318			11340	7724
	S 10					12506	7986	18837	14317	22003	17483	27069	22549	14176	9655
	S 12									20072	14648	25138	19713	17011	11586
IA750	S 06	9765	5936	18529	14700	22911	19081							11592	7763
	S 08			15942	10835	20323	15217	29087	23981	33469	28368			15458	10350
	S 10					17736	11353	26500	20117	30882	24499	37893	31510	19320	12938
	S 12									28294	20635	3505	27646	23184	15525
IA800	S 06	12227	8846	23224	19843	28722	25341							13149	9787
	S 08			19968	15460	25466	20958	36464	31955	41962	37454			17531	13023
	S 10					22211	16576	33208	27573	38706	33071	47504	41869	21914	16279
	S 12									35450	28688	44248	37486	26297	19535
IA1000	S 06	22715	14432	43073	34790	53252	44969							26285	18001
	S 08			37073	26028	47252	36207	67610	56565	77789	66744			35048	24001
	S 10					41252	27455	61610	47813	71789	57992	88075	74278	43799	30002
	S 12							55609	39051	65788	49230	82075	6517	52560	36002

Dimensions

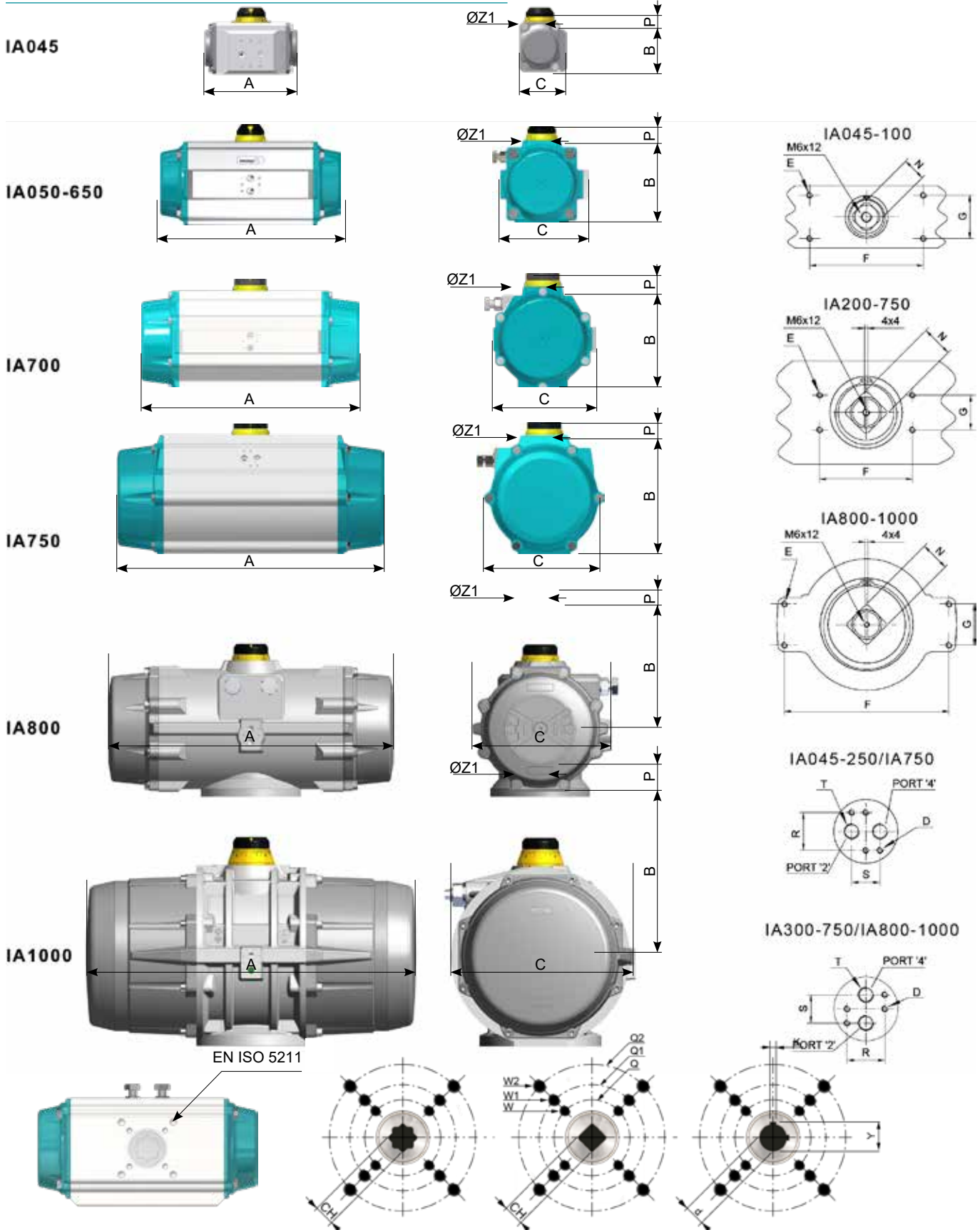

Dimensions

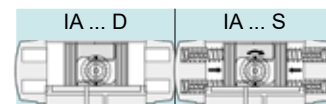

	A	B	C	D	E	F	G	N	P	R	S	T ¹⁾	Z1	V _o [in ³]	V _c [in ³]	t _o "	t _c "	[lb]	t _o "	t _c "	[lb]
IA 045	4,65	2,60	2,44	10-24UNC X 0,31	10-24UNC X 0,31	3,15	1,18	0,43	0,59/ 0,79	1,26	0,94	1/8"	1,65	3,66	6,1	0,15	0,20	1,65	0,20	0,25	1,98
IA 050	5,39	2,72	3,09	10-24UNC X 0,31	10-24UNC X 0,31	3,15	1,18	0,43	0,79	1,26	0,94	1/8"	1,65	5,5	9,2	0,2	0,25	2,5	0,25	0,3	2,8
IA 100	6,06	3,35	3,60	10-24UNC X 0,31	10-24UNC X 0,31	3,15	1,18	0,43	0,79	1,26	0,94	1/8"	1,65	9,8	15,9	0,25	0,3	3,8	0,3	0,35	4,2
IA 200	8,03	4,02	4,13	10-24UNC X 0,31	10-24UNC X 0,31	3,15	1,18	0,67	0,79	1,26	0,94	1/8"	1,65	18,9	29,9	0,3	0,35	6,5	0,4	0,5	7,4
IA 250	9,49	4,53	4,67	10-24UNC X 0,31	10-24UNC X 0,31	3,15	1,18	0,67	0,79	1,26	0,94	1/8"	1,65	31,1	47,6	0,4	0,5	9,3	0,5	0,6	10,6
IA 300	10,20	5,00	5,14	10-24UNC X 0,31	10-24UNC X 0,31	3,15	1,18	0,67	0,79	1,26	0,94	1/4"	1,65	43,3	67,7	0,5	0,6	12,6	0,7	0,9	14,6
IA 350	11,97	5,71	5,85	10-24UNC X 0,31	10-24UNC X 0,31	3,15	1,18	1,06	1,18	1,26	0,94	1/4"	2,28	72,6	109,8	0,7	0,8	19,4	0,9	1,1	22,5
IA 400	13,11	6,18	6,26	10-24UNC X 0,31	10-24UNC X 0,31	3,15	1,18	1,06	1,18	1,26	0,94	1/4"	2,28	94	142,8	0,9	1,1	23,6	1,2	1,4	27,8
IA 450	15,55	6,97	7,19	10-24UNC X 0,31	10-24UNC X 0,31	3,15	1,18	1,06	1,18	1,26	0,94	1/4"	2,66	147,1	230,7	1,2	1,4	34,2	1,5	1,8	41,2
IA 500	16,65	7,72	7,89	10-24UNC X 0,31	10-24UNC X 0,31	3,15	1,18	1,06	1,18	1,26	0,94	1/4"	2,66	191,6	300,2	1,5	1,7	43,2	1,8	2,1	52,2
IA 550	18,62	8,68	8,78	10-24UNC X 0,31	10-24UNC X 0,31	5,12	1,18	1,42	1,97	1,26	0,94	1/4"	3,15	260	420,5	2	2,2	55,1	2,4	2,8	72,8
IA 600	20,79	9,65	9,63	10-24UNC X 0,31	10-24UNC X 0,31	5,12	1,18	1,42	1,97	1,26	0,94	1/4"	3,15	362,5	577,3	2,7	3,2	81,6	3,5	4	99,2
IA 650	23,82	11,75	11,18	1/4-20UNC X 0,39	1/4-20UNC X 0,39	5,12	1,18	1,42	1,97	1,77	1,57	3/8"	4,53	610,2	927,3	3,5	4	123	4,1	4,6	157
IA 700	27,95	12,99	12,56	1/4-20UNC X 0,39	1/4-20UNC X 0,39	5,12	1,18	1,42	1,97	1,77	1,57	1/2"	4,53	884,8	1305	4	4,5	170	4,5	5	215
IA 750	31,97	15,08	14,61	1/4-20UNC X 0,39	1/4-20UNC X 0,39	5,12	1,18	1,42	1,97	1,77	1,57	1/2"	4,53	1220	2014	5	6	260	6	7	331
IA 800	33,66	16,14	16,46	1/4-20UNC X 0,39	1/4-20UNC X 0,39	5,12	1,18	1,42	1,97	1,77	1,57	1/2"	4,53	1526	2441	6	7	280	7,5	8,5	371
IA 1000	37,40	20,39	20,79	1/4-20UNC X 0,39	1/4-20UNC X 0,39	7,87	1,97	1,42	3,15	1,77	1,57	1/2"	5,31	2990	5126	8	9	375	10	11	525

1) BSP / ISO 228 / DIN 259

V(in³) Volume in inch³, V_o = OPEN, V_c = CLOSE

To calculate the air consumption, multiply the volume in litre by the supply pressure.

t_o / t_c t_o = opening time / t_c = closing time, in seconds

Dimensions

The above mentioned operating times are obtained under the following conditions:

- Air supply pressure min. 80 psi - at room temperature - medium clean air - actuator stroke 90° - actuator without resistance load

Caution: obviously, during operation, if one or more of the above listed criteria differ, the operating time will be different.

	EN ISO 5211	Q	Q1	Q2	W	W1	W2	CH* x l	CH♦ x l	d● x l	K	Y
IA 045	F03	1,41	-	-	10-24UNC X 0,31	-	-	0.35x0.43 0.43x0.47	-	-	-	-
	F04	1,65	-	-	10-24UNC X 0,31	-	-	0.35x0.43 0.43x0.47	-	-	-	-
IA 050	F03-F05	1,41	1,97	-	10-24UNC X 0,31	M6	-	0.43x0.47	-	-	-	-
	F04	1,65	-	-	M5	-	-	0.43x0.47	-	-	-	-
IA 100	F04	1,65	-	-	M5	-	-	0.43x0.75	-	-	-	-
	F05-F07	1,97	2,76	-	M6	M8	-	0.43x0.75 0.55x0.63	-	-	-	-
IA 200	F05-F07	1,97	2,76	-	M6	M8	-	0.55x0.75 0.67x0.75	0.43x0.75	-	-	-
IA 250	F05-F07	1,97	2,76	-	M6	M8	-	0.67x0.75	0.55x0.75	-	-	-
IA 300	F05-F07-F10	1,97	2,76	4,02	M6	M8	M10	0.67x0.98 0.87x0.98	0.55x0.75	-	-	-
IA 350	F07-F10	2,76	4,02	-	M8	M10	-	0.67x0.98 0.87x1.26	0.55x0.75	-	-	-
IA 400	F07-F10	2,76	4,02	-	M8	M10	-	0.87x1.26 1.06x1.14	0.67x0.98	-	-	-
IA 450	F10-F12	4,02	4,92	-	M10	M12	-	1.06x1.57	0.87x1.26	-	-	-
IA 500	F10-F12	4,02	4,92	-	M10	M12	-	1.06x1.57	0.87x1.57	-	-	-
IA 550	F10-F12	4,02	4,92	-	M10	M12	-	1.06x1.57	0.87x1.57	-	-	-
	F14	5,51	-	-	M16	-	-	1.42x1.5	-	-	-	-
IA 600	F10-F12	4,02	4,92	-	M10	M12	-	1.06x1.57	0.87x1.57	-	-	-
	F14	5,51	-	-	M16	-	-	-	ø1.77x2.56	0.55	1.93	
IA 650	F12	4,92	-	-	M12	-	-	0.87x1.57 1.06x1.57	-	-	-	-
	F14	5,51	-	-	M16	-	-	-	ø1.77x2.56	0.55	1.93	
IA 700	F12	4,92	-	-	M12	-	-	-	1.06x1.57	-	-	-
	F14	5,51	-	-	M16	-	-	-	1.06x1.57	ø1.77x2.56	0.55	1.93
	F16	6,5	-	-	M20	-	-	-	-	ø2.56x3.15	0.71	2.74
IA 750	F14	5,51	-	-	M16	-	-	-	1.06x2.76	ø1.77x3.15	0.55	1.93
	F16	6,5	-	-	M20	-	-	1.81x1.93	-	ø2.36x4.53	0.71	2.54
	F16-F25	6,5	10	-	M20	M16 (8x)	-	2.17x2.32	-	ø2.76x5.12	0.79	2.95
IA 800	F16-F25	6,5	10	-	M20	M16 (8x)	-	-	-	ø1.77x2.56	0.55	1.93
										ø2.36x3.15	0.71	2.54
										ø2.56x3.15	0.71	2.74
										ø2.76x3.15	0.79	2.95
										ø2.83x3.15	0.79	3.03
IA 1000	F16-F25-F30	6,5	10	11,73	M20	M16 (8x)	M20 (8x)	2.17x2.32 2.95x3.15	-	ø2.76x5.31	0.79	2.95
								-	ø3.15x5.31	0.87	3.37	

Accessories

Our wide range of accessories includes all kinds of position indicators, solenoid valves, positioners, Bus systems, manual emergency overdrives, etc. Please refer to the corresponding documentation or download it from our website.



Limit switches



Proximity switch
AS-Interface



Positioner



Solenoid valve

Actuator size, solenoid valve and air supply pipe according table below.

Actuator size	Solenoid valve	Air supply pipe
IA045 - 350	≥ DN 4	≥ DN 4
IA400 - 600	≥ DN 7	≥ DN 6
IA650 - 700	≥ DN 12	≥ DN 8
IA750 - 1000	≥ DN 12	≥ DN 10