

TL SERIES 30 KNIFE GATE VALVE



The SERIES 30 (TL) model knife gate valve is a bi-directional wafer type through-conduit valve designed for media with high consistency. The double seat design assures a non-clogging shut off on suspended solids in both flow directions. The valve is used in a wide range of demanding applications in industries such as Pulp & Paper, Wastewater Treatment Plants, Chemical plants, Power Plants, etc.

Product description:

- Bi-directional wafer type through-conduit knife gate valve
- Size range of DN2"-40" (larger sizes upon request). See Dimension Charts for pressure rating
- Rising & non-rising stem configurations available
- Standard flange connection: DIN PN10 (EN 1092-2) and ANSI B16.5 (class 150)
Others available upon request
- Manual (handwheel, chainwheel, lever and bevel gear), pneumatic (single and double-acting), electric and hydraulic actuation options available
- Directives: 2006/42/EC (MACHINES), 2014/68/EU (PED) Fluid: Group 1(b), 2 (Cat. I. mod. A) and 2014/34/EU (ATEX)

Features:

- Wafer type cast two-part bolted body. HMWPE sliders included in the stainless steel version for a smoother gate traveling
- Full port design for greater flow capacity and minimal pressure drop
- Stainless steel o-port design through-going gate, polished both sides to avoid jamming and seat damage
- Standard EPDM resilient seat. Metal-to-metal seat, other seat materials, as well as high performance rings and deflection cones available
- Dual packing with easy access and adjustable packing glands ensuring a tight seal. Long life PTFE impregnated synthetic fiber plus EPDM O-ring. Wide range of packing materials available
- RAL-5015 blue epoxy-coating on all cast iron/carbon steel components
- Automated valves provided with gate guards in accordance with EU Safety Standards. Only in EU
- Other options: bonnets, V-ports, flush ports, special materials, fabricated valves, etc.
- Actuation accessories: limit & proximity switches, mechanical stops, positioners, solenoid valves, manual overrides, locking devices, fail safe systems, stem extensions and floor stands

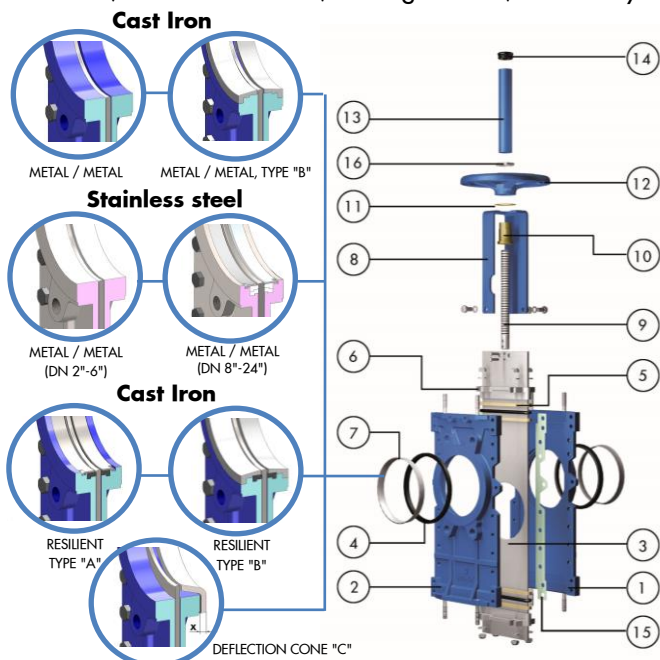

STANDARD PARTS LIST

Part	Material	
1	Body	GJL250 / GJS400 / CF8M
2	Body	GJL250 / GJS400 / CF8M
3	Gate	AISI 304 / AISI 316
4	Seat	Metal or EPDM
5	Packing	PTFE impreg. synth. fibre (ST)+O-ring
6	Gland Follower	Al (DN50-300) - Ductile Iron (DN350-1000) / CF8M
7	Seal Retainer Ring	AISI 304 / AISI 316
8	Yoke	Carbon steel - Epoxy coated
9	Stem	Stainless Steel
10	Stem Nut	Brass
11	Friction Washer	Brass
12	Handwheel	GJS400 (GGG40)
13	Stem Protector	Epoxy-coated carbon steel
14	Cap	Plastic
15	Gasket	Aramid fibres
16	Nut	Zinc plated carbon steel

* Refer to full catalogue for complete details

TL SERIES 30 KNIFE GATE VALVE



DIMENSIONS Handwheel Rising Stem

DN(“)	Pressures	A	B	C	D	E	F	ØG	H	O max.	Weight (lbs.)
2”	150 psi	1,57	5,98	4	4,33	5,07	1,85	8,86	16,88	9,13	26
2,5”	150 psi	1,57	6,57	4	4,52	5,79	1,85	8,86	17,75	10,04	30
3”0	150 psi	1,96	7,16	4	4,88	6,37	1,85	8,86	18,74	12,20	35
4”	150 psi	1,96	7,95	4	5,52	7,36	1,85	8,86	20,35	14,44	44
5”	150 psi	1,96	8,50	4	6	8,30	1,85	8,86	23,66	17,00	64
6”	115 psi	2,36	9,48	4	6,89	9,33	1,85	8,86	25,67	19,56	77
8”	115 psi	2,36	11,57	4,80	8,07	12,16	2,64	12,20	32,36	25	137
10”	115 psi	2,75	14,01	4,80	9,64	14,33	2,64	12,20	40,03	30,59	197
12”	90 psi	2,75	16,14	4,80	11,02	16,30	2,64	12,20	43,38	35,62	242
14”	90 psi	3,78	18,62	7,75	12	19,13	2,60	16,14	50,63	41,22	384
16”	90 psi	3,93	21,18	7,75	13,77	21,10	2,60	16,14	54,56	46,10	586
18”	75 psi	4,17	23,15	7,91	16,53	23,15	2,60	21,65	62,32	51,22	718
20”	60 psi	4,33	25,43	7,91	17,71	25,51	2,60	21,65	65,86	57,52	820
24”	60 psi	4,33	25,43	7,91	20,86	29,44	2,60	21,65	77,28	67,36	981

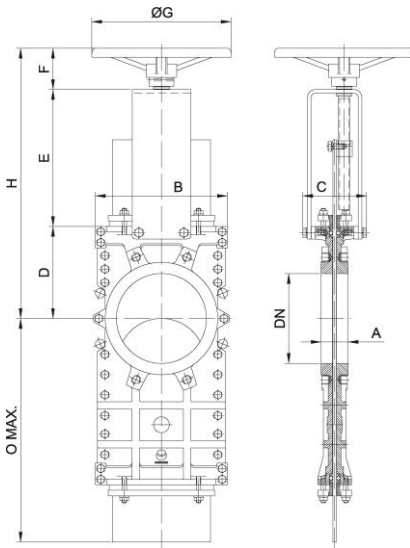
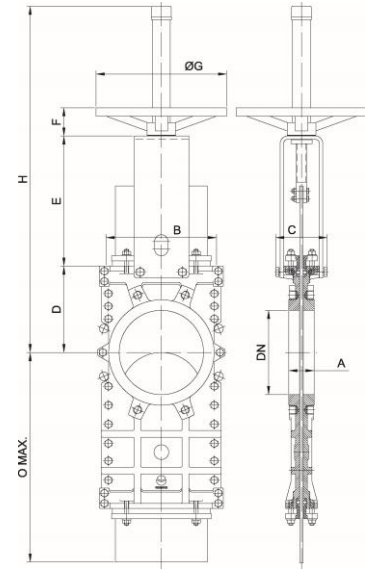

DIMENSIONS Handwheel Non Rising Stem

DN(“)	Pressures	A	B	C	D	E	F	ØG	H	O max.
2”	150 psi	1,57	5,98	4	4,33	5,66	2,48	8,86	12,48	9,13
2,5”	150 psi	1,57	6,57	4	4,52	6,33	2,48	8,86	13,34	10,04
3”0	150 psi	1,96	7,16	4	4,88	6,96	2,48	8,86	14,33	12,20
4”	150 psi	1,96	7,95	4	5,52	7,95	2,48	8,86	15,94	14,44
5”	150 psi	1,96	8,50	4	6	8,89	2,48	8,86	17,28	17,00
6”	115 psi	2,36	9,48	4	6,89	9,92	2,48	8,86	19,29	19,56
8”	115 psi	2,36	11,57	4,80	8,07	12,48	2,87	12,20	23,42	25
10”	115 psi	2,75	14,01	4,80	9,64	14,64	2,87	12,20	27,16	30,59
12”	90 psi	2,75	16,14	4,80	11,02	16,61	2,87	12,20	30,51	35,62
14”	90 psi	3,78	18,62	7,75	12	20,03	3,85	16,14	35,71	41,22
16”	90 psi	3,93	21,18	7,75	13,77	22,00	3,85	16,14	39,64	46,10
18”	75 psi	4,17	23,15	7,91	16,53	24,05	3,85	21,65	44,44	51,22
20”	60 psi	4,33	25,43	7,91	17,71	26,41	3,85	21,65	47,99	57,52
24”	60 psi	4,33	25,43	7,91	20,86	30,35	3,85	21,65	55,07	67,36

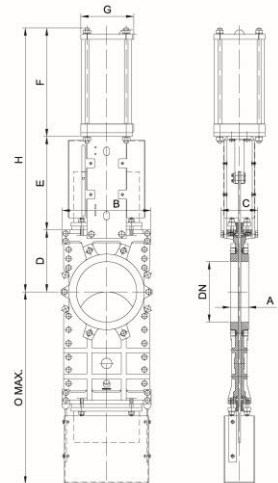

DIMENSIONS Pneumatic Actuator (D/A)

DN(“)	Pressures	A	B	C	D	O max.	E	F	G	H	Weight (lbs.)	Standard Cyl.	Connect.
2”	150 psi	1,57	5,98	4	4,33	9,13	5,07	7	4,53	16,41	30	C4”-2.44”	1/4” G
2,5”	150 psi	1,57	6,57	4	4,52	10,04	5,79	7,60	4,53	17,87	35	C4”-3.03”	1/4” G
3”0	150 psi	1,96	7,16	4	4,88	12,20	6,37	8,31	4,53	19,56	40	C4”-3.74”	1/4” G
4”	150 psi	1,96	7,95	4	5,52	14,44	7,36	9,09	4,53	21,96	51	C4”-4.52”	1/4” G
5”	150 psi	1,96	8,50	4	6	17,00	8,30	10,67	5,51	24,88	75	C5”-5.52”	1/4” G
6”	115 psi	2,36	9,48	4	6,89	19,56	9,33	11,65	5,51	27,87	90	C5”-6.61”	1/4” G
8”	115 psi	2,36	11,57	4,80	8,07	25	12,16	14,09	6,89	34,33	160	C6.30”-8.66”	1/4” G
10”	115 psi	2,75	14,01	4,80	9,64	30,59	14,33	16,85	8,66	40,82	231	C8”-10.62”	3/8” G
12”	90 psi	2,75	16,14	4,80	11,02	35,62	16,30	18,82	8,66	46,14	282	C8”-12.60”	3/8” G
14”	90 psi	3,78	18,62	7,75	12	41,22	20,08	21,61	10,90	53,50	456	C10”-14.76”	3/8” G
16”	90 psi	3,93	21,18	7,75	13,77	46,10	22,05	23,58	10,90	59,40	662	C10”-16.73”	3/8” G
18”	75 psi	4,17	23,15	7,91	16,53	51,22	23,94	26,77	15,03	67,24	833	C12”-18.70”	1/2” G
20”	60 psi	4,33	25,43	7,91	17,71	57,52	26,30	28,74	15,03	72,75	981	C12”-20.67”	1/2” G
24”	60 psi	4,33	25,43	7,91	20,86	67,36	31,33	34,64	17,48	86,85	1365	C14”-24.60”	3/4” G