



CE 1115



**VEE DN 10÷50**  
PVC-U

Easyfit 2-way ball valve

# VEE DN 10÷50

FIP and Giugiaro Design designed and developed VEE Easyfit, the innovative True Union ball valve with union nut tightening control, that permits simple and safe installation for reliable service in time.



## EASYFIT 2-WAY BALL VALVE

- **Patented Easyfit system:** innovative mechanism based on the principle of the bevel gear pair that controls valve union nut rotation during installation.
- Connection system for solvent weld and threaded joints
- **Valve material compatibility** (PVC-U) with water, drinking water and other food substance conveyance according to **current regulations**
- Easy radial dismounting allowing quick replacement of O-rings and ball seats without any need for tools
- **PN16 True Union valve body** made for PVC-U injection moulding and European Directive 97/23/EC compliant for PED pressurised equipment. ISO 9393 compliant test requirements
- **Short face to face dimension** according to international regulation ISO 7508 series III and European regulation EN 1452 "short" and fully interchangeable with previous VE series models
- Option of dismounting downstream pipes with the valve in the closed position
- Floating **full bore ball** with high surface finish made in CNC work stations to achieve precise dimensional tolerance and high surface finish

Technical specifications	
<b>Construction</b>	Easyfit 2-way True Union ball valve with locked carrier
<b>Size range</b>	DN 10 ÷ 50
<b>Nominal pressure</b>	PN 16 with water at 20 °C
<b>Temperature range</b>	0 °C ÷ 60 °C
<b>Coupling standards</b>	<p><b>Solvent welding:</b> EN ISO 1452, EN ISO 15493, BS 4346-1, DIN 8063, NF T54-028, ASTM D 2467, JIS K 6743. Pipe coupling capacity according to EN ISO 1452, EN ISO 15493, DIN 8062, NF T54-016, ASTM D 1785, JIS K 6741</p> <p><b>Thread:</b> ISO 228-1, DIN 2999, ASTM D 2467, JIS B 0203.</p>
<b>Reference standards</b>	<p><b>Construction criteria:</b> EN ISO 16135, EN ISO 1452, EN ISO 15493</p> <p><b>Test methods and requirements:</b> ISO 9393</p> <p><b>Installation criteria:</b> DVS 2204, DVS 2221, UNI 11242</p> <p><b>Actuator couplings:</b> ISO 5211</p>
<b>Valve material</b>	PVC-U
<b>Seal material</b>	EPDM (standard size O-Ring); PE (ball seats)
<b>Control options</b>	Manual control

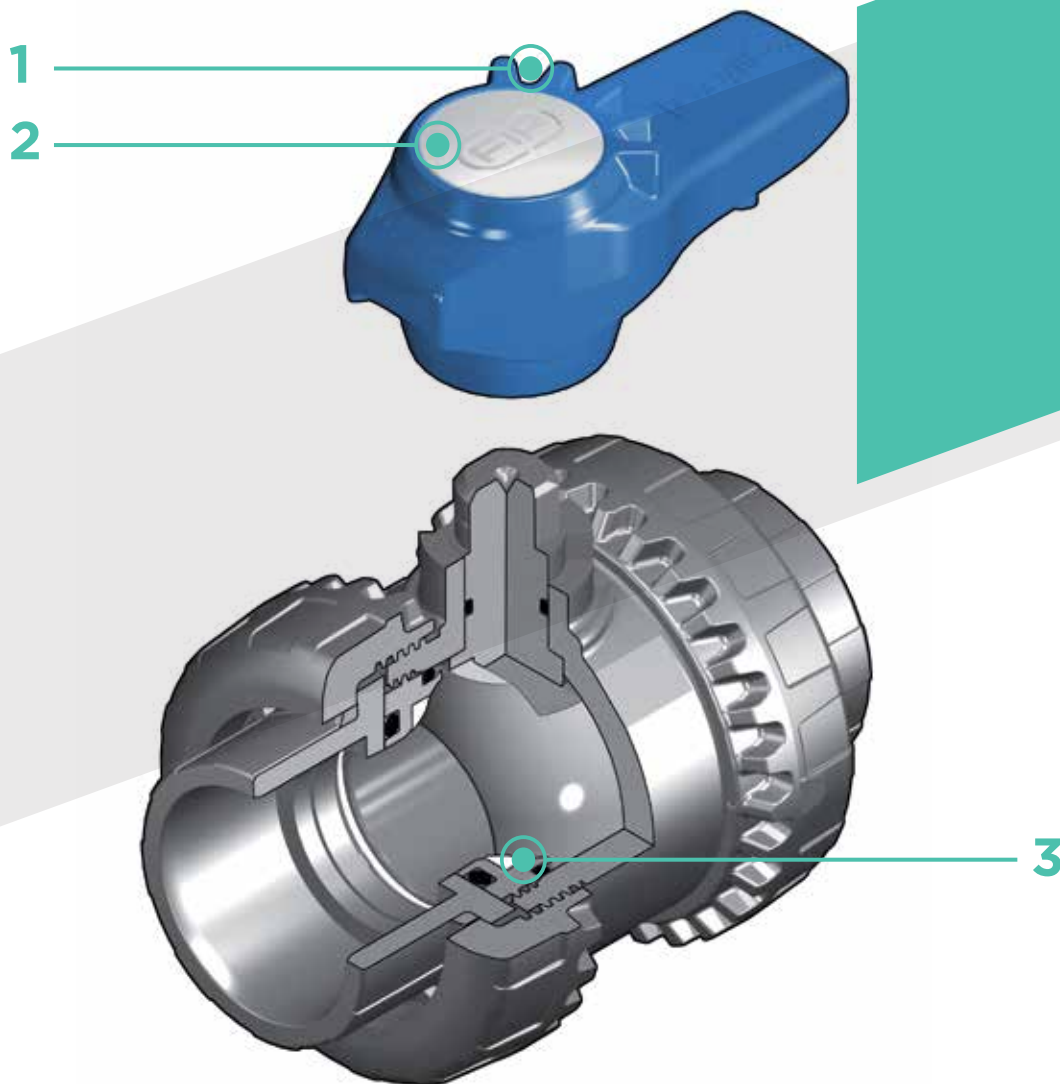

**1** Two position **Easyfit ergonomic multifunctional handle with union nut tightening control which can be used to adjust ball seat carriers**. Handle use is especially indicated for **maintenance** work where **space is limited** and hard to access

**2** Settings for the customisable Labelling System using the LCE module (available as an accessory). The grey protection plug housed on the handle can be replaced with the transparent plug and customisable tag holder with the LSE set (available as an accessory). The **customisation** lets you **identify the valve on the system** according to specific needs

**3** **The PE ball seat system with locked carrier** adjustable via Easyfit multifunctional handle or Easytorque adjustment kit (available as an accessory)

# TECHNICAL DATA

## PRESSURE VARIATION ACCORDING TO TEMPERATURE

For water and harmless fluids to which the material is classified as CHEMICALLY RESISTANT. In other cases, a reduction of the nominal PN pressure is required (25 years with safety factor).

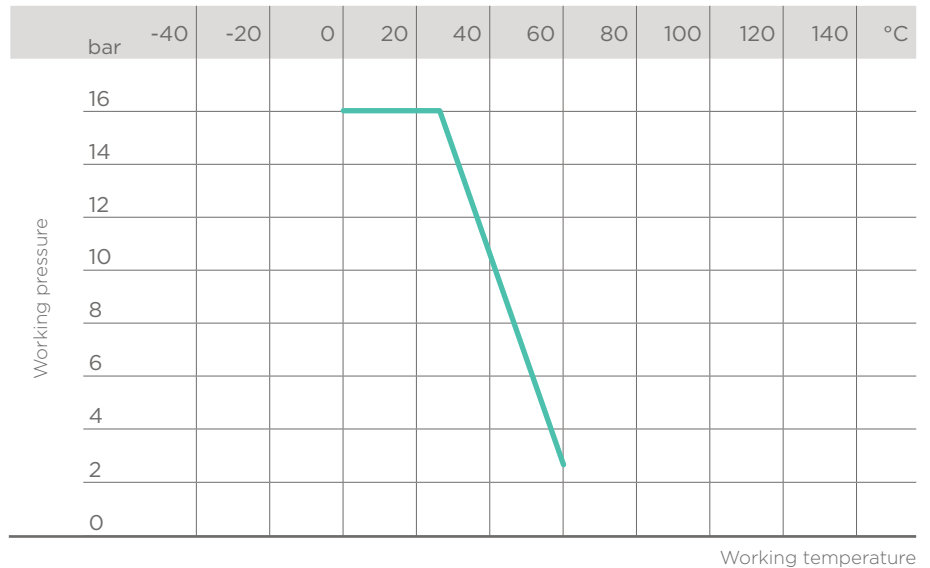

## PRESSURE DROP GRAPH

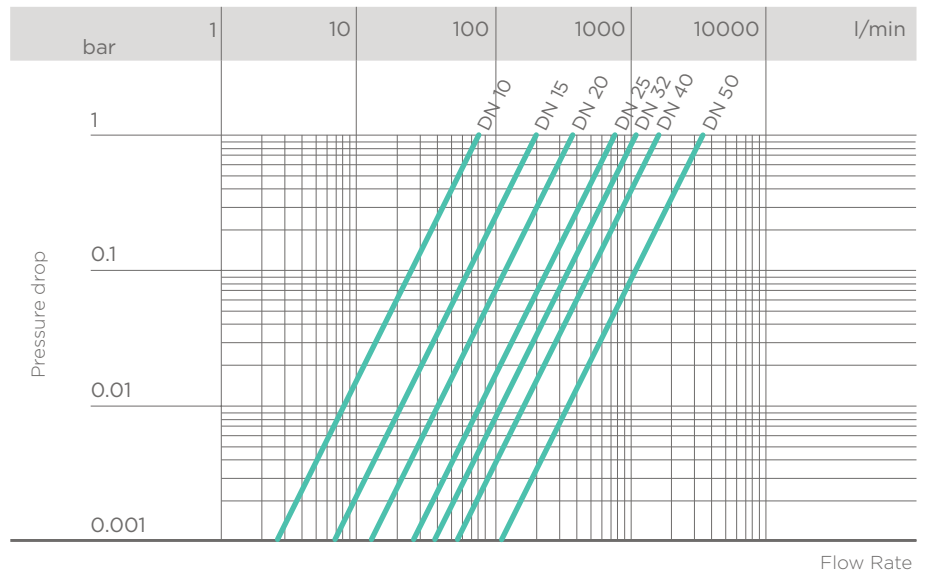

## K<sub>v</sub>100 FLOW COEFFICIENT

The K<sub>v</sub>100 flow coefficient is the Q flow rate of litres per minute of water at a temperature of 20°C that will generate Δp= 1 bar pressure drop at a certain valve position.

The K<sub>v</sub>100 values shown in the table are calculated with the valve completely open.

DN	10	15	20	25	32	40	50
K <sub>v</sub> 100 l/min	80	200	385	770	1100	1750	3400

The information in this leaflet is provided in good faith. No liability will be accepted concerning technical data that is not directly covered by recognised international standards. FIP reserves the right to carry out any modification. Products must be installed and maintained by qualified personnel.

# DIMENSIONS



## VEEIV

Easyfit 2-way ball valve with female ends for solvent welding, metric series

d	DN	PN	B	C	C <sub>1</sub>	E	H	L	Z	g	Code
16	10	16	49	64	44	54	82	14	54	180	VEEIV016E
20	15	16	49	64	44	54	82	16	50	175	VEEIV020E
25	20	16	62	78	55	63	91	19	53	260	VEEIV025E
32	25	16	71	87	60	72	103	22	59	365	VEEIV032E
40	32	16	82	102	72	85	120	26	68	565	VEEIV040E
50	40	16	92	109	76	100	139	31	77	795	VEEIV050E
63	50	16	110	133	94	118	174	38	98	1325	VEEIV063E



## VEEFV

Easyfit 2-way ball valve with BSP threaded female ends

R	DN	PN	B	C	C <sub>1</sub>	E	H	L	Z	g	Code
3/8"	10	16	49	64	44	54	82	11.4	59.2	180	VEEFV038E
1/2"	15	16	49	64	44	54	90	15	60	175	VEEFV012E
3/4"	20	16	62	78	55	63	93	16.3	60.4	260	VEEFV034E
1"	25	16	71	87	60	72	110	19.1	71.8	365	VEEFV100E
1" 1/4	32	16	82	102	72	85	127	21.4	84.2	565	VEEFV114E
1" 1/2	40	16	92	109	76	100	131	21.4	88.2	795	VEEFV112E
2"	50	16	110	133	94	118	161	25.7	109.6	1325	VEEFV200E



## VEELV

Easyfit 2-way ball valve with female ends for solvent welding, BS series

d	DN	PN	B	C	C <sub>1</sub>	E	H	L	Z	g	Code
1/2"	15	16	49	64	44	54	82	16.5	49	175	VEELV012E
3/4"	20	16	62	78	55	63	91	19	53	260	VEELV034E
1"	25	16	71	87	60	72	103	22.5	58	365	VEELV100E
1" 1/4	32	16	82	102	72	85	120	26	68	565	VEELV114E
1" 1/2	40	16	92	109	76	100	139	30	79	795	VEELV112E
2"	50	16	110	133	94	118	174	36	102	1325	VEELV200E



## VEEAV

Easyfit 2-way ball valve with female ends for solvent welding, ASTM series

d	DN	PN	B	C	C <sub>1</sub>	E	H	L	Z	g	Code
1/2"	15	16	49	64	44	54	96	22.5	51	175	VEEAV012E
3/4"	20	16	62	78	55	63	105	25.5	54	260	VEEAV034E
1"	25	16	71	87	60	72	117	28.7	59.5	365	VEEAV100E
1" 1/4	32	16	82	102	72	85	136	32	72	565	VEEAV114E
1" 1/2	40	16	92	109	76	100	147	35	77	795	VEEAV112E
2"	50	16	110	133	94	118	174	38.2	97.6	1325	VEEAV200E



## VEENV

Easyfit 2-way ball valve with female ends, NPT thread

R	DN	PN	B	C	C <sub>1</sub>	E	H	L	Z	g	Code
3/8"	10	16	49	64	44	54	82	13.7	54.6	180	VEENV038E
1/2"	15	16	49	64	44	54	90	17.8	54.4	175	VEENV012E
3/4"	20	16	62	78	55	63	93	18	57	260	VEENV034E
1"	25	16	71	87	60	72	110	22.6	64.8	365	VEENV100E
1" 1/4	32	16	82	102	72	85	127	25.1	76.8	565	VEENV114E
1" 1/2	40	16	92	109	76	100	131	24.7	81.6	795	VEENV112E
2"	50	16	110	133	94	118	161	29.6	101.8	1325	VEENV200E

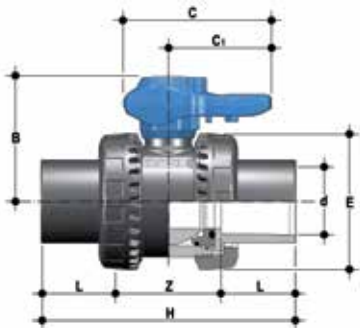

## VEEJV

Easyfit 2-way ball valve with female ends for solvent welding, JIS series

d	DN	PN	B	C	C <sub>1</sub>	E	H	L	Z	g	Code
1/2"	15	16	49	64	44	54	110	30	50	195	VEEJV012E
3/4"	20	16	62	78	55	63	123	35	53	285	VEEJV034E
1"	25	16	71	87	60	72	139	40	59	395	VEEJV100E
1" 1/4	32	16	82	102	72	85	156	44	68	600	VEEJV114E
1" 1/2	40	16	92	109	76	100	187	55	77	835	VEEJV112E
2"	50	16	110	133	94	118	228	63	102	1375	VEEJV200E



## VEEGV

Easyfit 2-way ball valve with female ends, JIS thread

R	DN	PN	B	C	C <sub>1</sub>	E	H	L	Z	g	Code
1/2"	15	16	49	64	44	54	82	16	50	175	VEEGV012E
3/4"	20	16	62	78	55	63	91	19	53	260	VEEGV034E
1"	25	16	71	87	60	72	103	22	59	365	VEEGV100E
1" 1/4	32	16	82	102	72	85	120	25	70	565	VEEGV114E
1" 1/2	40	16	92	109	76	100	139	26	87	795	VEEGV112E
2"	50	16	110	133	94	118	174	31	112	1325	VEEGV200E

## ACCESSORIES

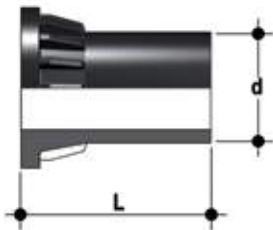

### CVDE

Long spigot PE100 end connectors for joints with electrofusion fittings or for butt welding

d	DN	PN	L	SDR	Code
20	15	16	55	11	CVDE11020
25	20	16	70	11	CVDE11025
32	25	16	74	11	CVDE11032
40	32	16	78	11	CVDE11040
52	40	16	84	11	CVDE11050
63	50	16	91	11	CVDE11063



### CVPV

Hose adaptor for ball valves

DN	PN	H	P <sub>1</sub>	P <sub>2</sub>	g	Code
40	16	246	50	52	840	CVPV050
50	16	273	60	64	1350	CVPV063



### CVRV

Threaded male end connectors for ball valves

DN	R	PN	CH	H	L	LT	Z	g	Code
40	1" 1/2	16	52	196	21.4	63.4	153.2	795	CVRV112
50	2"	16	62	226	25.7	69.2	174.6	1325	CVRV200



## EASYTORQUE KIT

Kit for union nut tightening adjustment and ball seat carrier for Easyfit DN 10÷50 valves.

d	DN	*Union nut tightening torque	*Seat carrier tightening torque	Code
3/8"-1/2"	10-15	5 N m - 3,69 Lbf ft	3 N m - 2,21 Lbf ft	KET01
3/4"	20	5 N m - 3,69 Lbf ft	3 N m - 2,21 Lbf ft	KET01
1"	25	6 N m - 4,43 Lbf ft	4 N m - 2,95 Lbf ft	KET01
1" 1/4	32	7 N m - 5,16 Lbf ft	4 N m - 2,95 Lbf ft	KET01
1" 1/2	40	8 N m - 5,90 Lbf ft	5 N m - 3,69 Lbf ft	KET01
2"	50	10 N m - 7,38 Lbf ft	6 N m - 4,43 Lbf ft	KET01

\*calculated in ideal installation conditions



## LCE

Transparent protection plug with tag holder

d	DN	Code
16	10	LCE020
20	15	LCE020
25	20	LCE025
32	25	LCE032
40	32	LCE040
50	40	LCE050
63	50	LCE063



## LSE

Customisation and label printing set for Easyfit handle made up of precut adhesive sheets and software for guided label creation.

d	DN	Code
16	10	LSE020
20	15	LSE020
25	20	LSE025
32	25	LSE032
40	32	LSE040
50	40	LSE050
63	50	LSE063



# CUSTOMISATION

The Easyfit VEE DN 10+50 valve is set for the customisable Labelling System.

This system lets you create special labels to insert in the handle. This makes it extremely easy to apply company logos, identification serial numbers or service indications such as, for example, the valve function in the system, the transported fluid, but also specific information for customer service, such as the customer name or installation date or location on the valves.

The grey protection plug (A) housed on the handle can be replaced with the specific LCE accessory module.

This module is made up of a rigid transparent water-resistant PVC plug (B) and white tag holder (C) made of the same material, one side of which bears the FIP logo (fig. 2).

The holder, inserted in the plug, can be removed and, once overturned, used for customisation by applying labels printed with the software supplied with the LSE set.

Proceed as follows to apply the label on the valve:

- 1) Extract the handle from the valve body and extract its grey plug (fig. 1)
- 2) Apply the adhesive label on tag holder included in the LCE set to align the profiles matching the tab position.
- 3) Insert tag holder in the transparent plug so that the label is protected from the elements.
- 4) Apply the transparent plug on the handle matching the two fittings (one narrow and one wide) with their housings (fig. 3).

Fig. 1



Fig. 2



Fig. 3

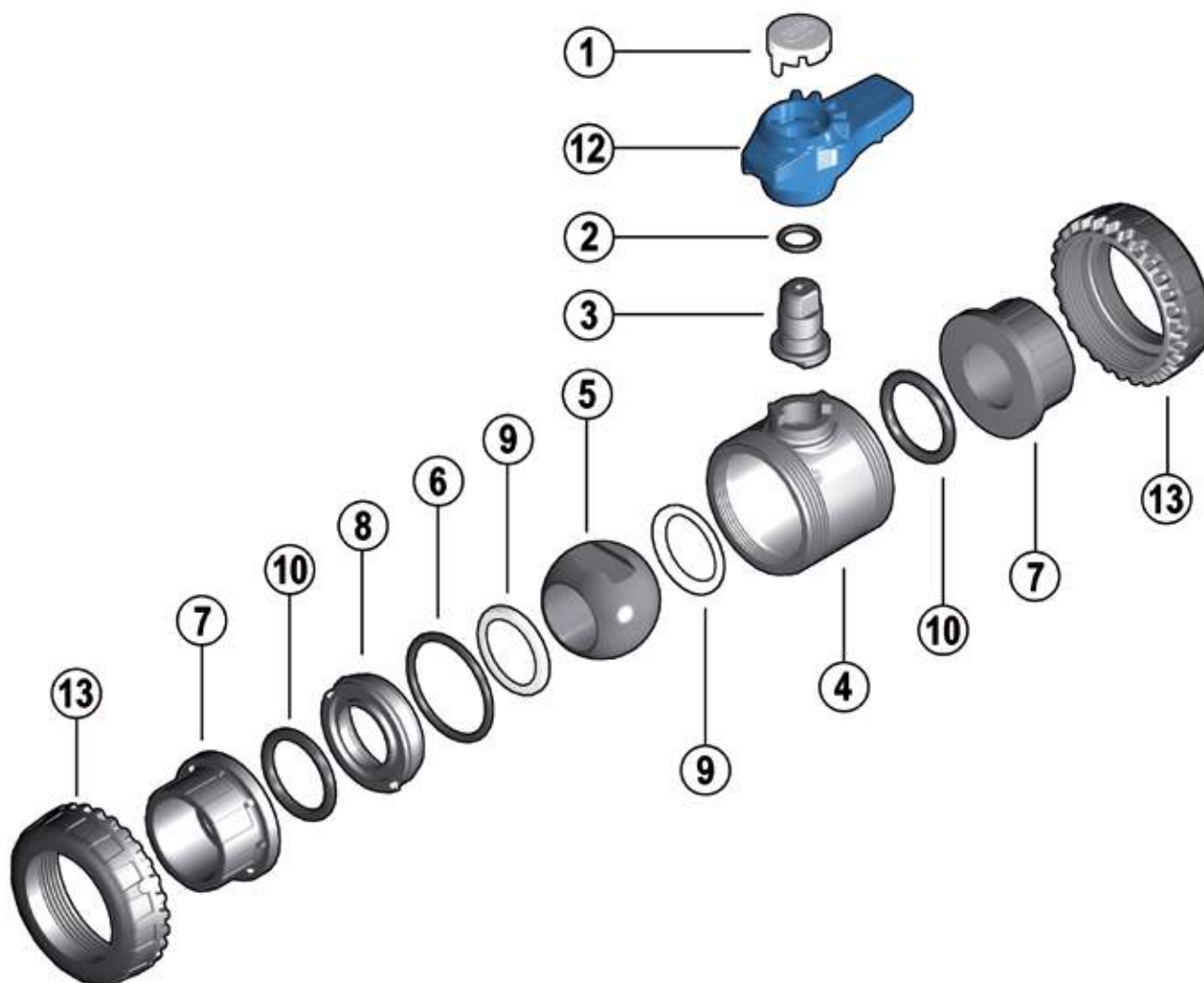

Fig. 4



# COMPONENTS

## EXPLODED VIEW



1 · Handle plug (PVC-U - 1)

2 · Stem O-Ring  
(EPDM - 2)\*

3 · Stem (PVC-U - 1)

4 · Body (PVC-U - 1)

5 · Ball (PVC-U - 1)

6 · Radial seal O-Ring  
(EPDM - 1)\*

7 · End connector (PVC-U - 2)

8 · Ball seat carrier  
(PVC-U - 1)

9 · Ball seat  
(PE - 2)

10 · Socket seal O-Ring  
(EPDM - 2)\*

12 · Handle (HIPVC - 1)

13 · Union nut (PVC-U - 2)

\* Spare parts

The component material and quantity supplied are indicated in the parentheses.

## DISMOUNTING

- 1) Isolate the valve from the line (release the pressure and empty the pipeline).
- 2) Fully unscrew the union nuts (13) from the valve body and slide the body out sideways (fig. 5-6).  
To do this, we recommend you use the Easyfit handle as a tool (fig. 9-10)
- 3) Before dismounting, hold the valve in a vertical position and open it 45° to drain any liquid that might remain.
- 4) After closing the valve, remove the handle (12) (fig. 7) and insert the two protrusions in the lower side in the two apertures and in the carrier passage bore (8), extracting it by turning counter-clockwise (fig. 8).
- 5) Press on the ball from the side opposite the "REGULAR" label, being sure not to scratch it, until the ball seat carrier exits (8), then extract the ball (5).
- 6) Press the stem (3) inwards until it exits the body.
- 7) Remove the O-Rings (2, 6, 10) and ball seats (9) extracting them from their seats, as illustrated in the exploded view.

## ASSEMBLY

- 1) All the O-Rings (2, 6, 10) must be inserted in their grooves as shown in the exploded view.
- 2) Insert the stem (3) from inside the body (4).
- 3) Place the ball seats (9) in the housings in the body (4) and in the carrier (8).
- 4) Insert the ball (5) rotating it to the closed position.
- 5) Screw the carrier (8) into the body and tighten up in the clockwise direction using the handle (12) to limit stop.
- 6) Position the valve between the end connectors (7) and tighten the union nuts (13) clockwise using the Easyfit multi-functional handle, being sure the socket seal O-Rings (10) do not exit the seats.
- 7) Position the handle (12) on the stem (3).



**Note:** during assembly operations, it is advisable to lubricate the rubber seals. Mineral oils are not recommended for this task as they react aggressively with EPDM rubber.

Fig. 5



Fig. 6



Fig. 7



Fig. 8



## INSTALLATION

Before proceeding with installation, please follow these instructions carefully:

- 1) Check that the pipes to be connected to the valve are aligned in order to avoid mechanical stress on the threaded joints.
- 2) Unscrew the union nuts (13) and slide them onto the pipe.
- 3) Solvent weld or screw the end connectors (7) onto the pipe segments.
- 4) Position the valve between the end connectors (fig. 6).  
Warning: if a high pressure test is required, always position the body with the "REGULAR" label upstream from the fluid direction.
- 5) Fit the union nuts on the valve body and manually tighten clockwise until they become hard to turn; do not use wrenches or other tools that can damage the union nut surfaces.
- 6) Extract the handle (12) from the valve body and extract its grey plug (1) (fig. 2)
- 7) Overturn the handle and insert in on the valve stem matching the handle teeth (A) with the union nut teeth (B) (fig. 9-10).
- 8) Turn the handle counter-clockwise to fully tighten the union nut. The rotation directions to tighten (TIGHTEN) and loosen (UNTIGHTEN) the union nuts are indicated on the handle (fig. 11). Generally, if pipes are not offset, one turn is sufficient for correct tightening.

9) Repeat point 7 for the other union nut.

Note: A small force applied on the handle develops a torque much higher than manual tightening.

You can also, using the Easytorque kit (fig. 12), supplied as an accessory, tighten union nuts using a torque wrench to quantify the force and thus monitor the stress applied to the thermoplastic threads according to the installation indications in the instructions enclosed with the kit.

10) Apply the plug (1) on the handle (12) matching the two fittings (one narrow and one wide) with the relevant housings on the handle (fig. 3).

11) Install the handle (12) on the stem (3) again.

12) If necessary, support the pipe with FIP pipe clip model ZIKM and DSM distance plates.

## WARNINGS

- If volatile liquid such as Hydrogen Peroxide (H<sub>2</sub>O<sub>2</sub>) or Sodium Hypochlorite (NaClO) is used, for safety reasons we recommend you contact the service centre. These liquids, upon vaporising, could create hazardous over pressures in the area between the body and ball.
- Do not use compressed air or other gases to test thermoplastic lines.
- Always avoid sudden closing manoeuvres and protect the valve from accidental manoeuvres.

Fig. 9



Fig. 10

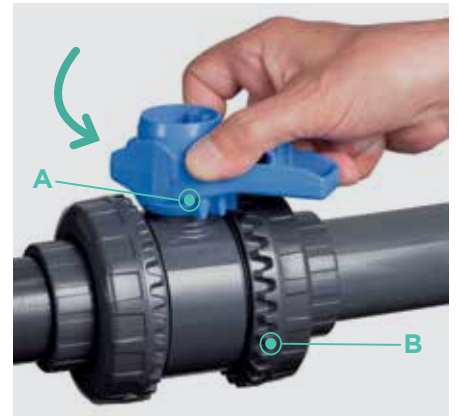

Fig. 11



Fig. 12





**Aliaxis**  
UTILITIES & INDUSTRY

**FIP - Formatura Iniezione Polimeri**

Loc. Pian di Parata, 16015 Casella Genova Italy

Tel. +39 010 96211

Fax +39 010 9621.209

info.fip@aliaxis.com

[www.fipnet.com](http://www.fipnet.com)



Code LEVAMAV