

VG SERIES 61 KNIFE GATE VALVE



The SERIES 61 (VG) model knife gate valve is a wafer type valve equipped with two metal reinforced rubber sleeves, designed for applications with abrasive slurries. The SER.61 (VG) slurry knife gate valve is mainly used in industries such as Mining, Chemical Plants, Power Plants, Wastewater Treatment Plants, etc.

Product description:

- Bi-directional wafer type knife gate valve
- Size range of DN 2"-36" (larger sizes upon request). See Dimension Charts for pressure rating
- Rising stem
- Standard flange connection: DIN PN10 (EN 1092-2) and ANSI B16.5 (class 150)
Others available upon request
- Manual (handwheel and bevel gear), pneumatic (single and double-acting), electric and hydraulic actuation options available
- Directives: 2006/42/EC (MACHINES), 2014/68/EU (PED) Fluid: Group 1(b), 2 (Cat. I. mod. A) and 2014/34/EU (ATEX)

Features:

- Wafer type cast monoblock body with two machined lateral openings where the sleeves fit perfectly. Grease nipples to lubricate the gate are standard
- Open at the bottom for draining purposes, also available with covers or splash guards
- Rectangular shaped stainless steel gate, polished both sides to reduce friction and to avoid seat damage
- Metal reinforced rubber sleeve seats, designed to allow maximum flexibility and minimum effort during gate travel
- EPDM packing as standard. Conventional leak proof packing also available
- RAL-5015 blue epoxy-coating on all cast iron/carbon steel components
- Automated valves provided with gate guards in accordance with EU Safety Standards. Only in EU
- Other options: open-closed lockout system, flush ports, special materials, fabricated valves, gate coatings, etc.
- Actuation accessories: limit & proximity switches, mechanical stops, positioners, solenoid valves, manual overrides, fail safe systems, stem extensions and floor stands

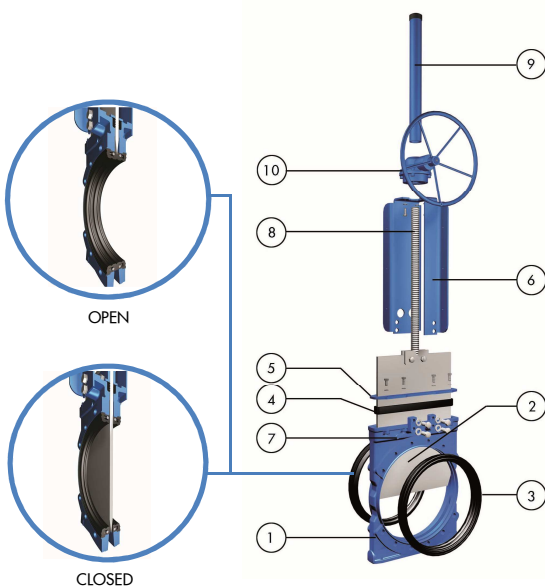

STANDARD PARTS LIST

Part	Materials:
1 Body	Ductile iron A536 (60-40-18) / 0.7040 / GJS 400
2 Gate	AISI 304 (1.4301) / AISI 316 (1.4401)
3 Sleeves	Natural rubber / EPDM
4 Packing	EPDM
5 Gland Follower	A570 GR.40 / 1.0044 Epoxy coated
6 Yoke	A570 GR.40 / 1.0044 Epoxy coated
7 Grease Nipple	Zinc coated carbon-steel
8 Stem	Stainless Steel
9 Stem Protector	A570 GR.40 / 1.0044 Epoxy coated
10 Bevel Gear	-

* Refer to full catalogue for complete details

VG SERIES 61 KNIFE GATE VALVE



DIMENSIONS Handwheel Rising Stem

DN(“)	Pressure	A1*	A2*	B	C	D	E	F	ØG	H	J
2”	150 psi	2.12	2.36	5.67	4	4.13	5.79	1.85	8.86	17.52	2.48
2 1/2”	150 psi	2.12	2.36	6.46	4	4.52	6.38	1.85	8.86	18.50	2.75
3”	150 psi	2.24	2.48	7.05	4	4.88	6.97	1.85	8.86	19.49	3.54
4”	150 psi	2.24	2.48	6.73	4.21	5.52	7.60	2.63	12.20	54.39	4
5”	150 psi	2.5	2.71	8	4.21	6	9.21	2.63	12.20	28	4.80
6”	150 psi	2.5	2.71	9.37	4.21	6.89	10.20	2.63	12.20	29.33	5.07
8”	150 psi	3	3.26	11.45	6.50	8.07	12.83	2.75	16.14	37.20	6.46
10”	150 psi	3	3.26	13.62	-	9.64	-	-	-	-	7.83
12”	150 psi	3.24	3.54	15.55	-	11.02	-	-	-	-	9.09
14”	150 psi	3.24	3.54	18	-	12.79	-	-	-	-	10.12
16”	150 psi	3.74	4.02	20.11	-	14	-	-	-	-	11.45
18”	90 -150 psi ⁽¹⁾	3.75	4.06	22.20	-	16.53	-	-	-	-	12.48
20”	90 -150 psi ⁽¹⁾	4.76	5.08	24.52	-	18.19	-	-	-	-	13.58
24”	90 -150 psi ⁽¹⁾	4.76	5.08	28.74	-	20.08	-	-	-	-	16.26

A1*: installed face to face

A2*: minimum required dimension for installation

⁽¹⁾ Duplex gate for 150 psi

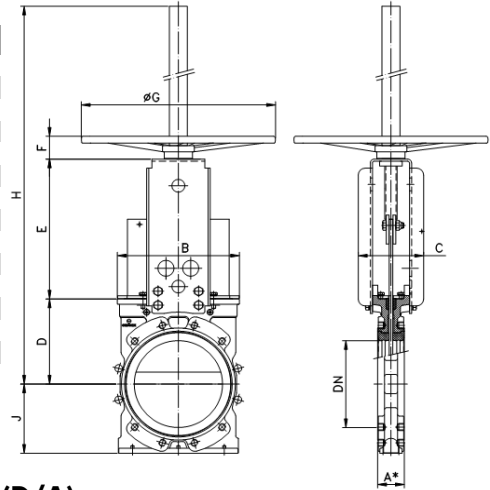

DIMENSIONS Pneumatic Actuator (D/A)

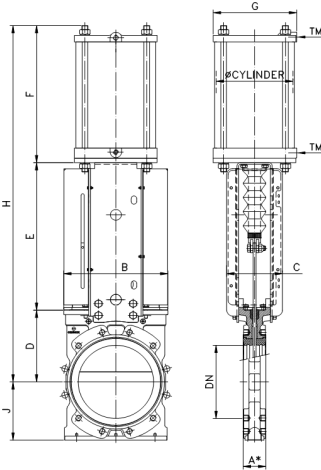

DN(“)	Pressure	A1*	A2*	B	C	D	E	F	G	H	J	Standard Cyl.	TM
2”	150 psi	2.12	2.36	5.67	4	4.13	8.30	8	4.58	20.31	2.48	C4"-3.15"	1/4"
2 1/2”	150 psi	2.12	2.36	6.46	4	4.52	8.70	8.42	4.58	21.65	2.75	C4"-3.74"	1/4"
3”	150 psi	2.24	2.48	7.05	4	4.88	10.12	9.44	5.51	24.45	3.5	C5"-4.33"	1/4"
4”	150 psi	2.24	2.48	6.73	4.21	5.52	10.63	10.16	5.51	27.08	4	C5"-5.12"	1/4"
5”	150 psi	2.5	2.71	8	4.21	6	14.52	11.73	6.89	32.16	4.80	C6.30"-6.30"	1/4"
6”	150 psi	2.5	2.71	9.37	4.21	6.89	15.55	12.72	6.89	35.15	5.08	C6.30"-7.28"	1/4"
8”	150 psi	3	3.26	11.45	6.50	8.07	18.26	15.67	8.66	42.01	6.46	C8"-9.44"	3/8"
10”	150 psi	3	3.26	13.62	7.28	9.64	19.88	18.50	10.90	48.03	7.83	C10"-11.42"	3/8"
12”	150 psi	3.24	3.54	15.55	10	11.02	25.83	21.18	13.18	58.03	9.10	C12"-13.58"	1/2"
14”	150 psi	3.24	3.54	18	11.42	12.79	28.03	25.60	17.48	66.42	10.12	C14"-15.55"	3/4"
16”	150 psi	3.74	4.02	20.11	11.42	14	30.27	27.75	17.48	71.81	11.46	C14"-17.72"	3/4"
18”	90 -150 psi ⁽¹⁾	3.75	4.06	22.20	11.42	16.53	32.99	30.19	20.27	79.72	12.48	C16"-19.68"	3/4"
20”	90 -150 psi ⁽¹⁾	4.76	5.08	24.52	11.42	18.19	35.31	33.03	20.27	86.53	13.58	C16"-22.04"	3/4"
24”	90 -150 psi ⁽¹⁾	4.76	5.08	28.74	11.42	20.08	38.93	36.25	20.27	95.27	16.26	C16"-25.78"	3/4"

A1*: installed face to face

A2*: minimum required dimension for installation

⁽¹⁾ Duplex gate for 150 psi

DIMENSIONS Electric Actuator Rising Stem

DN(“)	Pressure	A1*	A2*	B	C	D	E	F	ØG	H	I	J	L	M	N	Torque (ft.LBS)
2”	150 psi	2.12	2.36	5.67	4	4.13	5.70	5.63	6.30	23.74	10.43	9.80	2.44	9.37	2.48	14.8
2 1/2”	150 psi	2.12	2.36	6.46	4	4.52	6.29	5.63	6.30	24.72	10.43	9.80	2.44	9.37	2.75	14.8
3”	150 psi	2.24	2.48	7.05	4	4.88	7.28	5.63	6.30	26.06	10.43	9.80	2.44	9.37	3.54	22.2
4”	150 psi	2.24	2.48	6.73	4.21	5.52	7.68	5.63	6.30	27.08	10.43	9.80	2.44	9.37	3.93	25.81
5”	150 psi	2.5	2.71	8	4.21	6	9.25	5.63	6.30	43.31	10.43	9.80	2.44	9.37	4.80	29.50
6”	150 psi	2.5	2.71	9.37	4.21	6.89	10.24	5.63	6.30	45.59	10.43	9.80	2.44	9.37	5.08	36.87
8”	150 psi	3	3.26	11.45	6.50	8.07	13.00	6.10	7.87	50.07	11.14	10	2.55	9.76	6.45	51.8
10”	150 psi	3	3.26	13.62	7.28	9.64	15.94	6.10	7.87	54.60	11.14	10	2.55	9.76	7.83	81.4
12”	150 psi	3.24	3.54	15.67	10	11.02	18.19	6.10	7.87	57.24	11.14	10	2.55	9.76	9.09	88.50
14”	150 psi	3.24	3.54	18	10	12.79	20.47	6.22	12.40	63.07	15.31	13.22	3.54	11.25	10.12	117.99
16”	150 psi	3.74	4.02	20.11	10.68	14	22.83	6.22	12.40	66.53	15.31	13.22	3.54	11.25	11.46	177.09
18”	90 -150 psi ⁽¹⁾	3.75	4.06	22.20	11.42	16.53	25.39	6.22	16	71.78	15.31	13.22	3.54	11.25	12.48	147.49
20”	90 -150 psi ⁽¹⁾	4.76	5.08	24.52	11.42	18.19	27.75	6.22	16	75.78	15.31	13.34	3.54	11.25	13.58	221.27
24”	90 -150 psi ⁽¹⁾	4.76	5.08	28.74	11.42	20.08	31.65	6.22	20	83.46	16.93	14.37	4.53	11.93	16.26	295.02
28”	75 psi	7.12	7.48	33.26	12.60	22.68	36.81	6.22	16	109.05	15.31	13.34	3.58	11.25	18.70	331.86
30”	75 psi	7.36	7.67	36.22	12.60	23.82	38.07	7.48	20	113.38	16.93	14.37	4.53	11.93	20	405.60
32”	75 psi	8.11	8.42	39.68	12.60	25.78	42.44	7.48	20	119.48	16.93	14.37	4.53	11.93	21.65	442.48
36”	75 psi	8.87	9.21	43.50	12.60	27.75	46.06	7.48	20	125.20	16.93	14.37	4.53	11.93	24.40	553.10

A1*: installed face to face

A2*: minimum required dimension for installation

⁽¹⁾ Duplex gate for 150 psi

