



VKD DN 10÷50
PP-H

DUAL BLOCK® 2-way ball valve

VKD DN 10÷50

FIP has developed a VKD DUAL BLOCK® 2-WAY ball valve to introduce a high reference standard in thermosplastic valve design. VKD is a True Union ball valve that meets the most stringent needs required by industrial applications.

DUAL BLOCK® 2-WAY BALL VALVE

- Connection system for weld, threaded and flanged joints
- Patented **SEAT STOP®** ball seat carrier system that lets you micro-adjust ball seats and minimise axial force effects
- Easy radial disassembly allowing quick replacement of O-rings and ball seats without any need for tools
- **PN10 True Union valve body** made for PP-H injection moulding equipped with built-in bores for actuation. ISO 9393 compliant test requisites
- Option of disassembling downstream pipes with the valve in the closed position
- Floating **full bore ball** with high surface finish
- **Integrated bracket** for valve anchoring
- Ball seat carriers can be adjusted using the **Easytorque adjustment kit**



Technical specifications	
Construction	2-way True Union ball valve with locked carrier and lockable union nuts.
Size range	DN 10 ÷ 50
Nominal pressure	PN 10 with water at 20° C
Temperature range	0 °C ÷ 100 °C
Coupling standards	<p>Welding: EN ISO 15494. Can be coupled to pipes according to EN ISO 15494</p> <p>Thread: ISO 228-1, DIN 2999</p> <p>Flanging system: ISO 7005-1, EN 1092-1, EN ISO 15494, EN 558-1, DIN 2501, ANSI B16.5 cl.150</p>
Reference standards	<p>Construction criteria: EN ISO 16135, EN ISO 15494</p> <p>Test methods and requirements: ISO 9393</p> <p>Installation criteria: DVS 2202-1, DVS 2207-11, DVS 2208-1, UNI 11318</p> <p>Actuator couplings: ISO 5211</p>
Valve material	PP-H
Seal material	EPDM, FPM (standard size O-Rings); PTFE (ball seats)
Control options	Manual control; electric actuator; pneumatic actuator

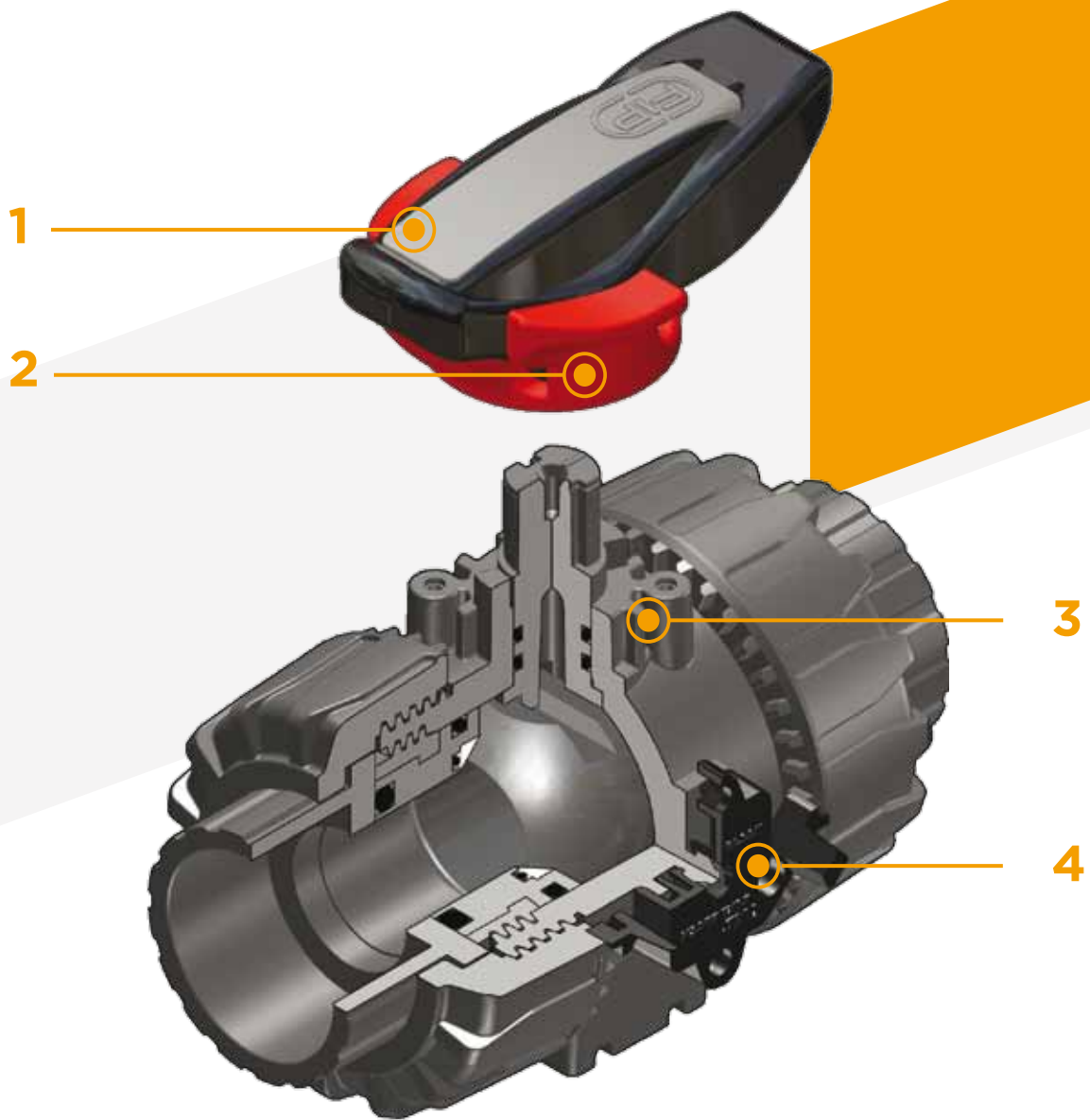

- 1** Ergonomic HIPVC handle equipped with **removable tool** to **adjust the ball seat carrier**.
- 2** **Handle lock 0°- 90° SHKD** (available as an accessory) ergonomically operable during service and lockable

3 Robust **integrated bracket for valve anchoring**, for easy and quick automation even after valve installation on the system via the Power Quick module (optional)

4 **DUAL BLOCK®** patented lock system that ensures union nut tightening hold even in severe conditions such as vibrations or heat dilation

TECHNICAL DATA

PRESSURE VARIATION ACCORDING TO TEMPERATURE

For water and non-hazardous fluids with regard to which the material is classified as CHEMICALLY RESISTANT. In other cases, a reduction of the nominal pressure PN is required (25 years with safety factor).

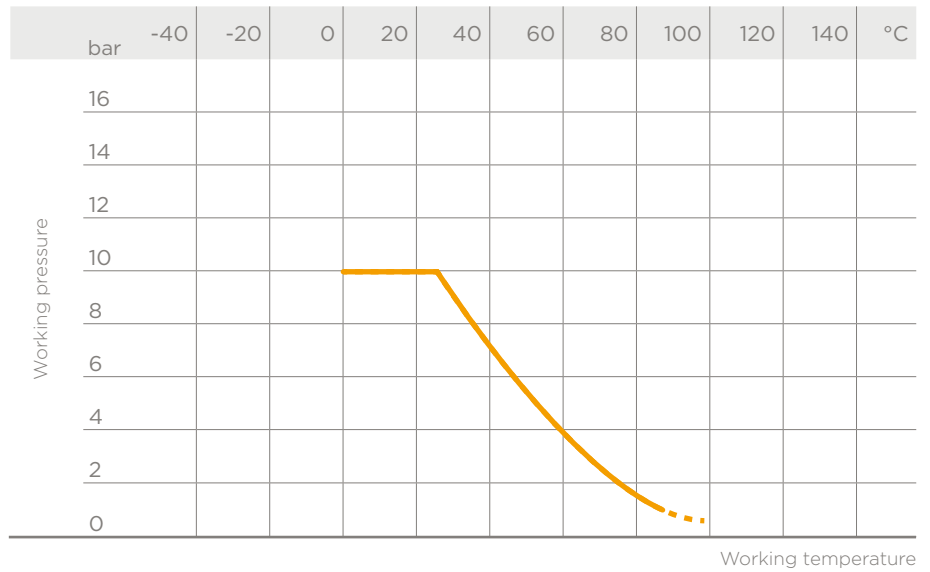

PRESSURE DROP GRAPH

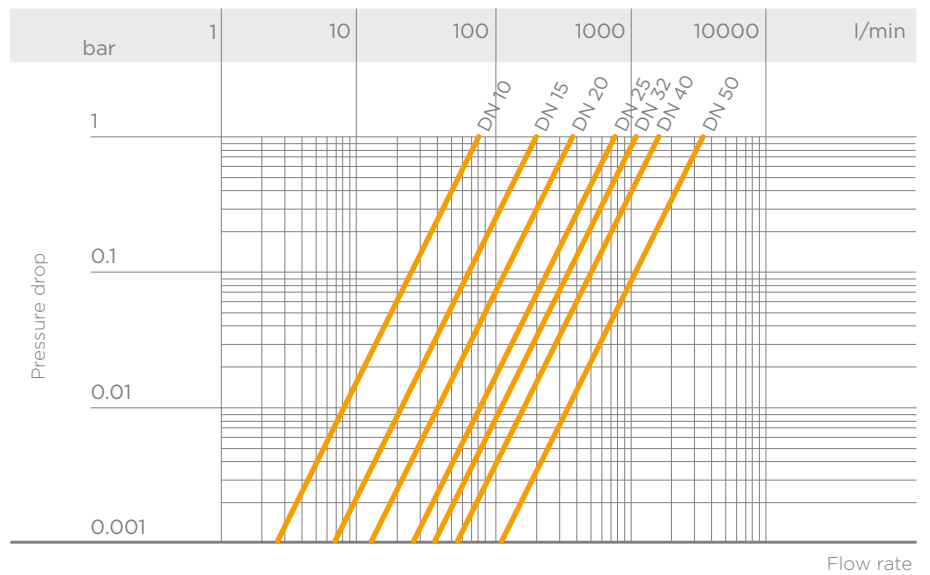

K_v100 FLOW COEFFICIENT

The K_v100 flow coefficient is the Q flow of litres per minute of water at a temperature of 20°C that will generate Δp= 1 bar pressure drop at a certain valve position.

The K_v100 values shown in the table are calculated with the valve completely open.

DN	10	15	20	25	32	40	50
K _v 100 l/min	80	200	385	770	1100	1750	3400

OPERATING TORQUE AT MAXIMUM WORKING PRESSURE

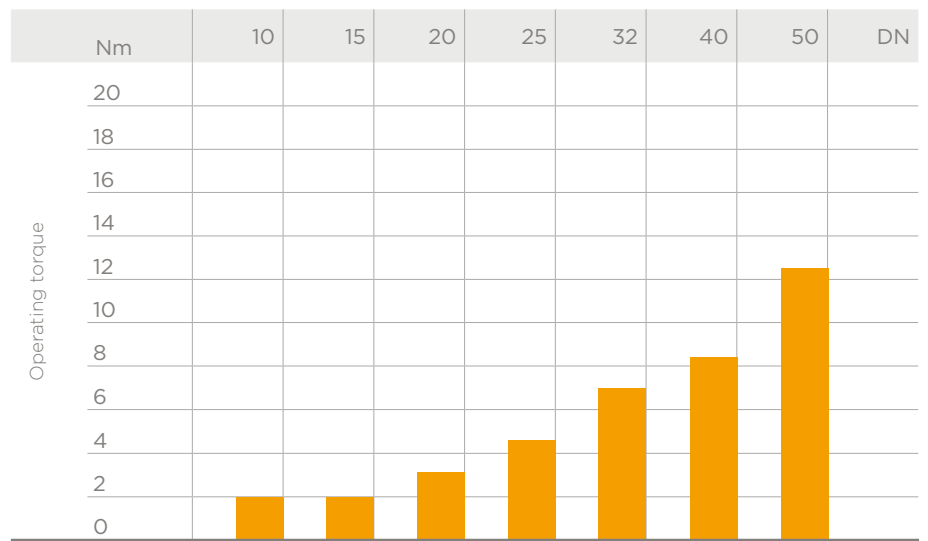

The information in this leaflet is provided in good faith. No liability will be accepted concerning technical data that is not directly covered by recognised international standards. FiP reserves the right to carry out any modification. Products must be installed and maintained by qualified personnel.

DIMENSIONS

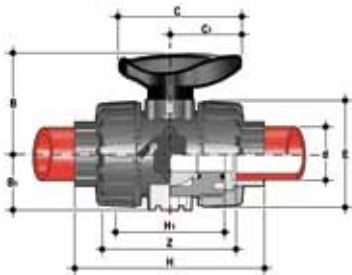

VKDIM

Dual Block® 2-way ball valve with female ends for socket welding, metric series

d	DN	PN	B	B ₁	C	C ₁	E	H	H ₁	Z	g	EPDM Code	FPM Code
16	10	10	54	29	67	40	54	102	65	74.5	150	VKDIM016E	VKDIM016F
20	15	10	54	29	67	40	54	102	65	73	145	VKDIM020E	VKDIM020F
25	20	10	65	34.5	85	49	65	114	70	82	218	VKDIM025E	VKDIM025F
32	25	10	69.5	39	85	49	73	126	78	90	298	VKDIM032E	VKDIM032F
40	32	10	82.5	46	108	64	86	141	88	100	480	VKDIM040E	VKDIM040F
50	40	10	89	52	108	64	98	164	93	117	682	VKDIM050E	VKDIM050F
63	50	10	108	62	134	76	122	199	111	144	1166	VKDIM063E	VKDIM063F

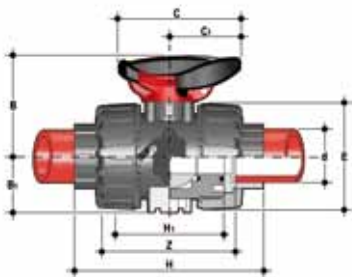

VKDIM/SHX

Dual Block® 2-way ball valve with handle lock and STAINLESS steel threaded inserts with female ends for socket welding, metric series

d	DN	PN	B	B ₁	C	C ₁	E	H	H ₁	Z	g	EPDM Code	FPM Code
16	10	10	54	29	67	40	54	102	65	74.5	160	VKDIMSHX016E	VKDIMSHX016F
20	15	10	54	29	67	40	54	102	65	73	155	VKDIMSHX020E	VKDIMSHX020F
25	20	10	65	34.5	85	49	65	114	70	82	228	VKDIMSHX025E	VKDIMSHX025F
32	25	10	69.5	39	85	49	73	126	78	90	308	VKDIMSHX032E	VKDIMSHX032F
40	32	10	82.5	46	108	64	86	141	88	100	490	VKDIMSHX040E	VKDIMSHX040F
50	40	10	89	52	108	64	98	164	93	117	692	VKDIMSHX050E	VKDIMSHX050F
63	50	10	108	62	134	76	122	199	111	144	1176	VKDIMSHX063E	VKDIMSHX063F

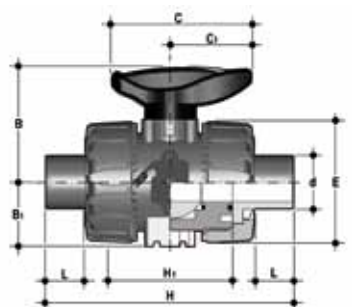

VKDDM

DUAL BLOCK® 2-way ball valve with male ends for socket welding, metric series

d	DN	PN	B	B ₁	C	C ₁	E	H	H ₁	L	g	EPDM Code	FPM Code
16	10	10	54	29	67	40	54	-	-	-	-	VKDDM016E	VKDDM016F
20	15	10	54	29	67	40	54	124	65	16	153	VKDDM020E	VKDDM020F
25	20	10	65	34.5	85	49	65	144	70	18	222	VKDDM025E	VKDDM025F
32	25	10	69.5	39	85	49	73	154	78	20	303	VKDDM032E	VKDDM032F
40	32	10	82.5	46	108	64	86	174	88	22	485	VKDDM040E	VKDDM040F
50	40	10	89	52	108	64	98	194	93	23	672	VKDDM050E	VKDDM050F
63	50	10	108	62	134	76	122	224	111	29	1176	VKDDM063E	VKDDM063F

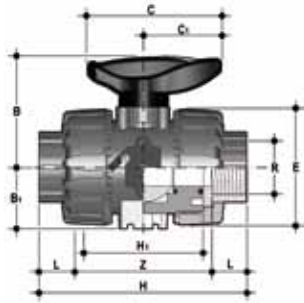

VKDFM

Dual Block® 2-way ball valve with BSP threaded female ends

R	DN	PN	B	B ₁	C	C ₁	E	H	H ₁	L	Z	g	EPDM Code	FPM Code
1/2"	15	10	54	29	67	40	54	110	65	15	80	145	VKDFM012E	VKDFM012F
3/4"	20	10	65	34.5	85	49	65	116	70	16	83	220	VKDFM034E	VKDFM034F
1"	25	10	69.5	39	85	49	73	134	78	19	96	298	VKDFM100E	VKDFM100F
1 1/4"	32	10	82.5	46	108	64	86	153	88	21	110	488	VKDFM114E	VKDFM114F
1 1/2"	40	10	89	52	108	64	98	156	93	21	113	682	VKDFM112E	VKDFM112F
2"	50	10	108	62	134	76	122	186	111	26	135	1181	VKDFM200E	VKDFM200F

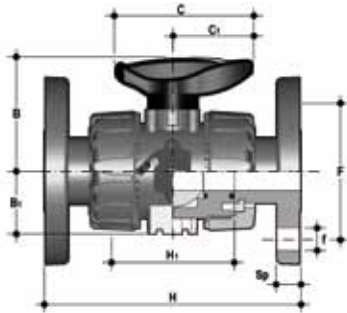

VKDOM

DUAL BLOCK® 2-way ball valve with fixed flanges, drilled EN/ISO/DIN PN 10/16. Face to face according to EN 558-1

d	DN	PN	B	B ₁	C	C ₁	F	f	H	H ₁	Sp	U	g	EPDM Code	FPM Code
20	15	10	54	29	67	40	65	14	130	65	11	4	387	VKDOM020E	VKDOM020F
25	20	10	65	34.5	85	49	75	14	150	70	14	4	504	VKDOM025E	VKDOM025F
32	25	10	69.5	39	85	49	85	14	160	78	14	4	697	VKDOM032E	VKDOM032F
40	32	10	82.5	46	108	64	100	18	180	88	14	4	1075	VKDOM040E	VKDOM040F
50	40	10	89	52	108	64	110	18	200	93	16	4	1346	VKDOM050E	VKDOM050F
63	50	10	108	62	134	76	125	18	230	111	16	4	2060	VKDOM063E	VKDOM063F

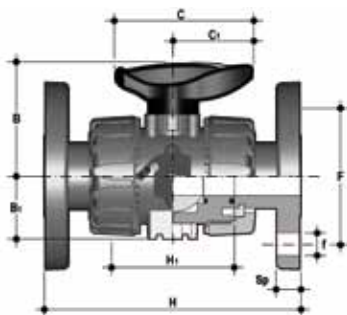

VKDOAM

DUAL BLOCK® 2-way ball valve with fixed flange, drilled ANSI B16.5 cl.150#FF

Size	DN	PN	B	B ₁	C	C ₁	F	f	H	H ₁	Sp	U	g	EPDM Code	FPM Code
1/2"	15	10	54	29	67	40	60.3	15.9	143	65	11	4	387	VKDOAM012E	VKDOAM012F
3/4"	20	10	65	34.5	85	49	69.9	15.9	172	70	14	4	504	VKDOAM034E	VKDOAM034F
1"	25	10	69.5	39	85	49	79.4	15.9	187	78	14	4	697	VKDOAM100E	VKDOAM100F
1 1/4"	32	10	82.5	46	108	64	88.9	15.9	190	88	14	4	1075	VKDOAM114E	VKDOAM114F
1 1/2"	40	10	89	52	108	64	98.4	15.9	212	93	16	4	1346	VKDOAM112E	VKDOAM112F
2"	50	10	108	62	134	76	120.7	19.1	234	111	16	4	2060	VKDOAM200E	VKDOAM200F

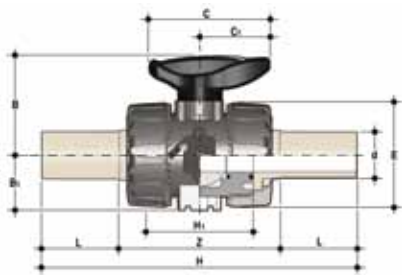

VKDBM

DUAL BLOCK® 2-way ball valve with long spigot male ends in PP-H SDR 11 for butt welding or electrofusion (CVDM)

d	DN	PN	B	B ₁	C	C ₁	E	H	H ₁	L	Z	g	EPDM Code	FPM Code
20	15	10	54	29	67	40	54	175	65	41	93	220	VKDBM020E	VKDBM020F
25	20	10	65	35	85	49	65	210	70	52	106	340	VKDBM025E	VKDBM025F
32	25	10	70	39	85	49	73	226	78	55	116	443	VKDBM032E	VKDBM032F
40	32	10	83	46	108	64	86	243	88	56	131	593	VKDBM040E	VKDBM040F
50	40	10	89	52	108	64	98	261	93	58	145	945	VKDBM050E	VKDBM050F
63	50	10	108	62	134	76	122	293	111	66	161	1607	VKDBM063E	VKDBM063F

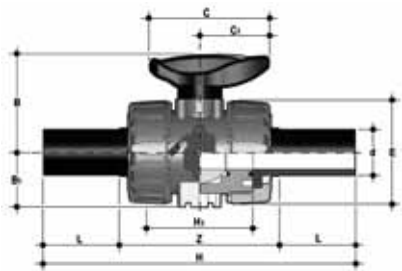

VKDBEM

DUAL BLOCK® 2-way ball valve with PE100 SDR 11 male end connectors for butt welding or electrofusion (CVDE)

d	DN	PN	B	B ₁	C	C ₁	E	H	H ₁	L	Z	g	EPDM Code	FPM Code
20	15	10	54	29	67	40	54	175	65	41	94	210	VKDBEM020E	VKDBEM020F
25	20	10	65	34.5	85	49	65	210	70	52	106	325	VKDBEM025E	VKDBEM025F
32	25	10	69.5	39	85	49	73	226	78	55	117	420	VKDBEM032E	VKDBEM032F
40	32	10	82.5	46	108	64	86	243	88	56	131	570	VKDBEM040E	VKDBEM040F
50	40	10	89	52	108	64	98	261	93	58	145	900	VKDBEM050E	VKDBEM050F
63	50	10	108	62	134	76	122	293	111	66	161	1500	VKDBEM063E	VKDBEM063F

ACCESSORIES

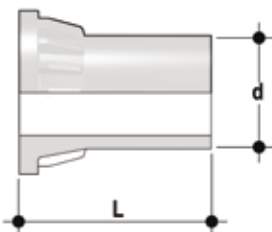

CVDM

End connectors in PP-H SDR 11 PN 10, long spigot, for butt welding

d	DN	PN	L	SDR	Code
20	15	10	55	11	CVDM11020
25	20	10	70	11	CVDM11025
32	25	10	74	11	CVDM11032
40	32	10	78	11	CVDM11040
52	40	10	84	11	CVDM11050
63	50	10	91	11	CVDM11063

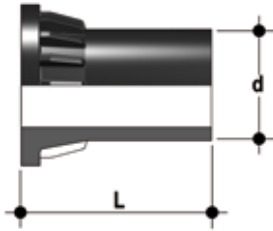

CVDE

Long spigot PE100 SDR 11 PN 16 end connectors for joints with electrofusion fittings or for butt welding

d	DN	PN	L	SDR	Code
20	15	16	55	11	CVDE11020
25	20	16	70	11	CVDE11025
32	25	16	74	11	CVDE11032
40	32	16	78	11	CVDE11040
52	40	16	84	11	CVDE11050
63	50	16	91	11	CVDE11063



SHKD

Handle block kit 0° - 90° lockable

d	DN	Code
16 - 20	10 - 15	SHKD020
25 - 32	20 - 25	SHKD032
40 - 50	32 - 40	SHKD050
63	50	SHKD063

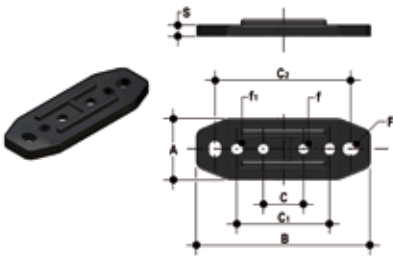

PMKD

Wall mounting plate

d	DN	A	B	C	C ₁	C ₂	F	f	f ₁	S	Code
16	10	30	86	20	46	67.5	6.5	5.3	5.5	5	PMKD1
20	15	30	86	20	46	67.5	6.5	5.3	5.5	5	PMKD1
25	20	30	86	20	46	67.5	6.5	5.3	5.5	5	PMKD1
32	25	30	86	20	46	67.5	6.5	5.3	5.5	5	PMKD1
40	32	40	122	30	72	102	6.5	6.3	6.5	6	PMKD2
50	40	40	122	30	72	102	6.5	6.3	6.5	6	PMKD2
63	50	40	122	30	72	102	6.5	6.3	6.5	6	PMKD2



PSKD

Stem extension

d	DN	A	A ₁	A ₂	E	B	B ₁	B _{min}	Code
16	10	32	25	32	54	70	29	139.5	PSKD020
20	15	32	25	32	54	70	29	139.5	PSKD020
25	20	32	25	40	65	89	34.5	164.5	PSKD025
32	25	32	25	40	73	93.5	39	169	PSKD032
40	32	40	32	50	86	110	46	200	PSKD040
50	40	40	32	50	98	116	52	206	PSKD050
63	50	40	32	59	122	122	62	225	PSKD063



EASYTORQUE KIT

Kit for ball seat carrier tightening adjustment for DUAL BLOCK® DN 10÷50 series valves

d	DN	Tightening torque recommended*	Code
3/8"-1/2"	10-15	3 N m - 2,21 Lbf ft	KETO1
3/4"	20	4 N m - 2,95 Lbf ft	KETO1
1"	25	5 N m - 3,69 Lbf ft	KETO1
1 1/4"	32	5 N m - 3,69 Lbf ft	KETO1
1 1/2"	40	7 N m - 5,16 Lbf ft	KETO1
2"	50	9 N m - 6,64 Lbf ft	KETO1

*calculated in ideal installation conditions

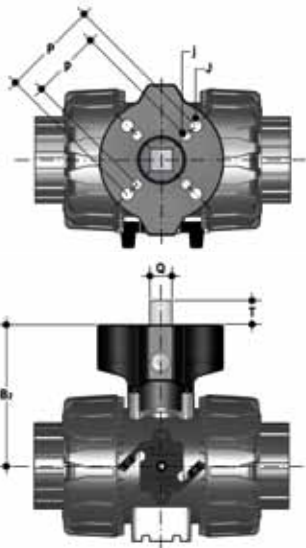

POWER QUICK CP

The valve can be equipped with pneumatic actuators, using the PP-GR module reproducing the drilling pattern foreseen by ISO 5211

d	DN	B ₂	Q	T	p x j	P x J	Code
16	10	58	11	12	F03 x 5,5	F04 x 5,5	PQCP020
20	15	58	11	12	F03 x 5,5	F04 x 5,5	PQCP020
25	20	69	11	12	*F03 x 5,5	F05 x 6,5	PQCP025
32	25	74	11	12	*F03 x 5,5	F05 x 6,5	PQCP032
40	32	91	14	16	F05 x 6,5	F07 x 8,5	PQCP040
50	40	97	14	16	F05 x 6,5	F07 x 8,5	PQCP050
63	50	114	14	16	F05 x 6,5	F07 x 8,5	PQCP063

*F04 x 5.5 on request

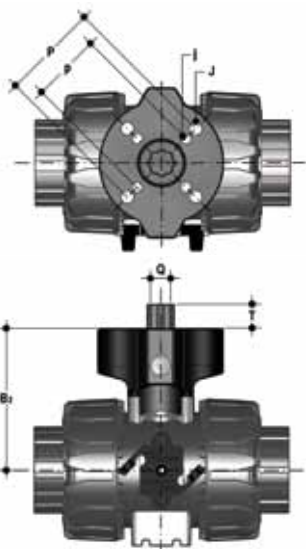

POWER QUICK CE

The valve can be equipped with electric actuators, using the PP-GR module reproducing the drilling pattern provided for by ISO 5211

d	DN	B ₂	Q	T	p x j	P x J	Code
16	10	58	14	16	F03 x 5,5	F04 x 5,5	PQCE020
20	15	58	14	16	F03 x 5,5	F04 x 5,5	PQCE020
25	20	69	14	16	*F03 x 5,5	F05 x 6,5	PQCE025
32	25	74	14	16	*F03 x 5,5	F05 x 6,5	PQCE032
40	32	91	14	16	F05 x 6,5	F07 x 8,5	PQCE040
50	40	97	14	16	F05 x 6,5	F07 x 8,5	PQCE050
63	50	114	14	16	F05 x 6,5	F07 x 8,5	PQCE063

*F04 x 5.5 on request

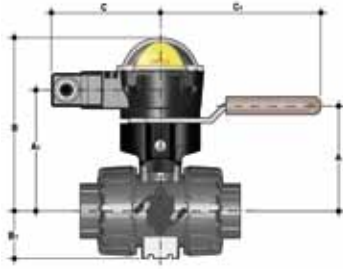

MSKD

MSKD is a limit switch box with electromechanical or inductive micro switches to remotely signal the valve position. Manual valve installation is possible using the Power Quick actuation module.

The box can be assembled on the VKD valve even if already installed on the system.

d	DN	A	A ₁	B	B ₁	C	C ₁	Code electromechanical	Code inductive	Code Namur
16	10	58	85	132.5	29	88.5	134	MSKD1M	MSKD1I	MSKD1N
20	15	58	85	132.5	29	88.5	134	MSKD1M	MSKD1I	MSKD1N
25	20	70.5	96	143.5	34.5	88.5	134	MSKD1M	MSKD1I	MSKD1N
32	25	74	101	148.5	39	88.5	134	MSKD1M	MSKD1I	MSKD1N
40	32	116	118	165.5	46	88.5	167	MSKD2M	MSKD2I	MSKD2N
50	40	122	124	171.5	52	88.5	167	MSKD2M	MSKD2I	MSKD2N
63	50	139	141	188.5	62	88.5	167	MSKD2M	MSKD2I	MSKD2N

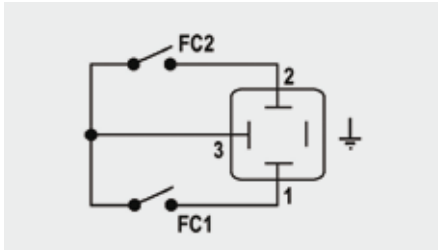

Electromechanical

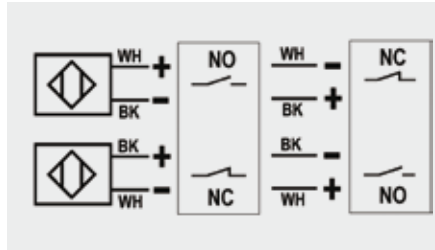

Inductive

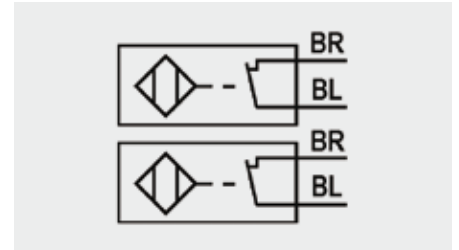

Namur

WH = white; BK = black; BL = blue; BR = brown

Type switches	Flow rate	Lifetime [drives]	Rated operating	Rated voltage	Operating current	Voltage drop	Empty current	Protection rate
Electromechanical	250 V - 5 A	3 x 10 ⁷	-	-	-	-	-	IP65
Inductive	-	-	5 ÷ 36 V	-	4 ÷ 200 mA	< 4,6 V	< 0,8 mA	IP65
Namur*	-	-	7,5 ÷ 30 V DC**	8,2 V DC	< 30 mA**	-	-	IP65

* To be used with an amplifier

** Outside areas with explosion risks

FASTENING AND SUPPORTING



All valves, whether manual or actuated, must be adequately supported in many applications.

The VKD valve series is therefore provided with an integrated bracket that permits direct anchoring of the valve body without the need of other components.

For wall installation, dedicated PMKD mounting plates which are available as accessories can be used. These plates should be fastened to the valve before wall installation.

PMKD plates also allow VKD valve alignment with FIP ZIKM pipe clips as well as allowing different sizes of valves to be aligned.

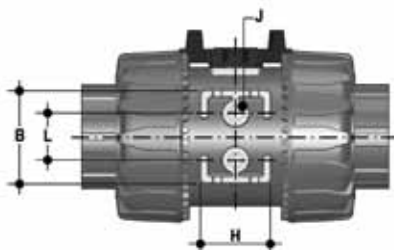

d	DN	B	H	L	J*
16	10	31.5	27	20	M4 x 6
20	15	31.5	27	20	M4 x 6
25	20	40	30	20	M4 x 6
32	25	40	30	20	M4 x 6
40	32	50	35	20	M6 x 10
50	40	50	35	20	M6 x 10
63	50	60	40	20	M6 x 10

* With threaded inserts

COMPONENTS

EXPLODED VIEW

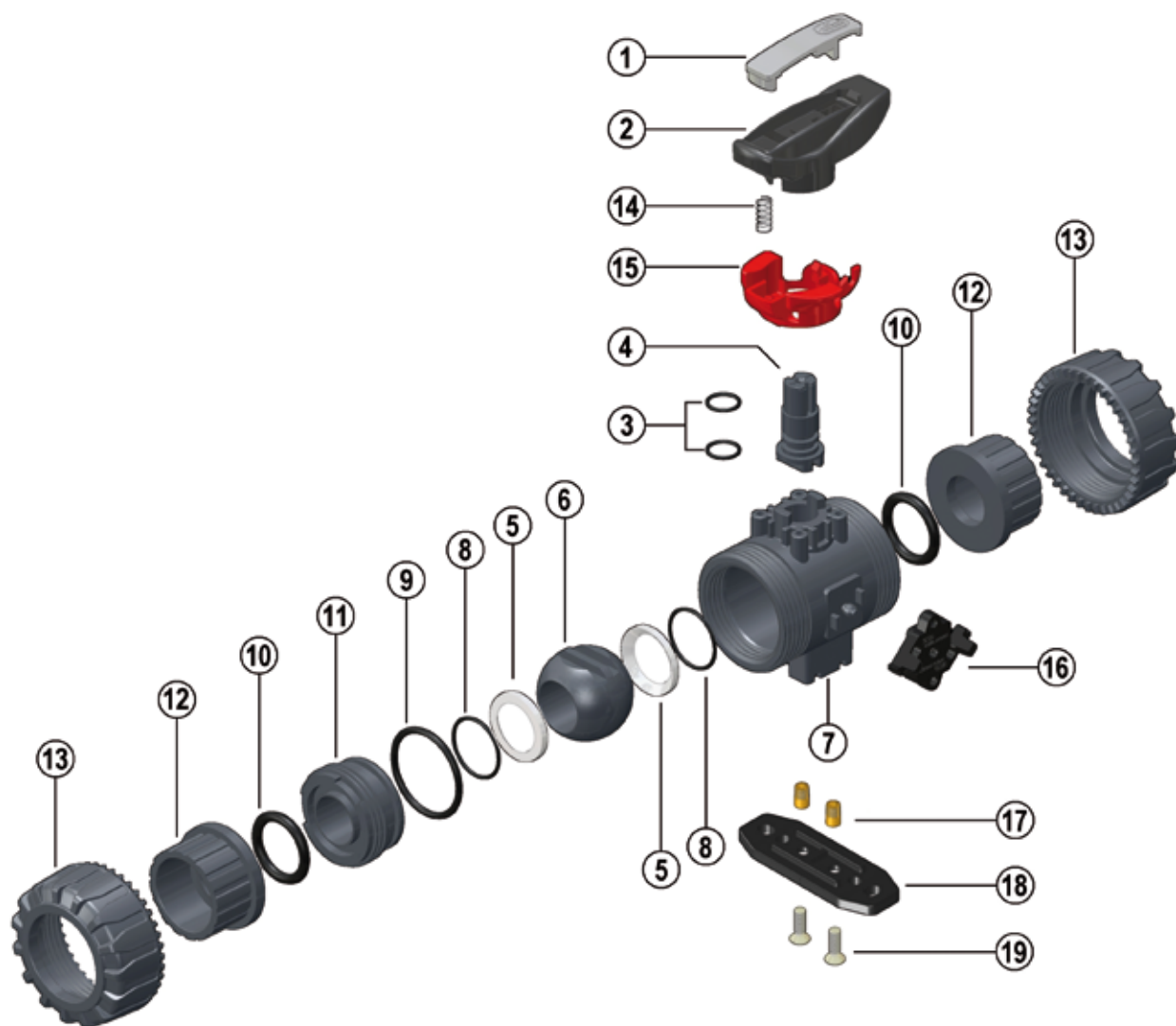

- 1 · Handle insert (PVC - 1)
- 2 · Handle (HIPVC - 1)
- 3 · Stem O-ring (EPDM or FPM - 2)*
- 4 · Stem (PP-H - 1)
- 5 · Ball seat (PTFE - 2)*
- 6 · Ball (PP-H - 1)
- 7 · Body (PP-H - 1)

- 8 · Ball seat O-Ring (EPDM or FPM - 2)*
- 9 · Radial seal O-Ring (EPDM or FPM - 1)*
- 10 · Socket seal O-Ring (EPDM or FPM - 2)*
- 11 · Ball seat carrier (PP-H - 1)
- 12 · End connector (PP-H - 2)*

- 13 · Union nut (PP-H - 2)
- 14 · Spring (Stainless steel - 1)**
- 15 · Handle safety block (PP-GR - 1)**
- 16 · DUAL BLOCK® (POM - 1)
- 17 · Threaded inserts (STAINLESS steel or Brass - 2)**
- 18 · Distance plate (PP-GR - 1)**
- 19 · Screw (Stainless steel - 2)**

* Spare parts

** Accessories

The material of the component and the quantity supplied are indicated between brackets

DISASSEMBLY

- 1) Isolate the valve from the line (release the pressure and empty the pipeline).
- 2) Unlock the union nuts by pressing the lever on the DUAL BLOCK® (16) along the axis and separate it from the union nut (fig. 1-2). IT is also possible to completely remove the locking device from the valve body.
- 3) Fully unscrew the union nuts (13) and extract the body sideways.
- 4) Before disassembling, hold the valve in a vertical position and open it 45° to drain any liquid that might remain.
- 5) After closing the valve, remove the special insert (1) from the handle (2) and push the two projecting ends into the corresponding recesses on the ball seat carrier (11). Rotate the stop ring anti-clockwise to extract it (fig. 3-4).
- 6) Pull the handle (2) upwards to remove it from the valve stem (4).
- 7) Press on the ball from the side opposite the "REGULAR - ADJUST" label, being sure not to scratch it, until the ball seat carrier exits (11), then extract the ball (6).
- 8) Press the stem (4) inwards until it exits the valve body.
- 9) Remove the O-Ring (3, 8, 9, 10) and PTFE ball seats (5) extracting them from their grooves, as illustrated in the exploded view.

ASSEMBLY

- 1) All the O-rings (3, 8, 9, 10) must be inserted in their grooves as shown in the exploded view.
- 2) Insert the stem (4) from inside the valve body (7).
- 3) Place the PTFE ball seats (5) in the housings in the body (7) and in the ball seat carrier (11).
- 4) Insert the ball (6) rotating it to the closed position.
- 5) Screw the carrier (11) into the body and tighten up in the clockwise direction using the handle (2) to limit stop.
- 6) Insert the valve between the end connectors (12) and tighten the union nuts (13) making sure that the socket seal O-rings (10) do not exit their seats.
- 7) The handle (2) should be placed on the valve stem (4).



Note: during assembly, it is advisable to lubricate the rubber seals. Mineral oils are not recommended for this task as they react aggressively with EPDM rubber.

Fig. 1



Fig. 2



Fig. 3



Fig. 4



INSTALLATION

Before proceeding with installation, please follow these instructions carefully:

- 1) Check that the pipes to be connected to the valve are aligned in order to avoid mechanical stress on the threaded joints.
- 2) Check that the DUAL BLOCK® union nut locking device (16) is installed on the valve body.
- 3) To release the union nuts, axially press the release lever to separate the lock and then unscrew it in the counter-clockwise direction.
- 4) Unscrew the union nuts (13) and insert them on the pipe segments.
- 5) Solvent weld or screw the end connectors (12) onto the pipe ends.
- 6) Position the valve body between the end connectors and fully tighten the union nuts (13) manually by rotating clockwise without using wrenches or other tools that could damage the union nut surface.
- 7) Lock the union nuts by returning the DUAL BLOCK® to its housing, pressing on it until the hinges lock on the nuts.

8) If necessary, support the pipework with FIP pipe clips or by means of the carrier built into the valve itself (see paragraph "fastening and supporting").

The VKD valve can be equipped with a handle lock to prevent ball rotation (supplied separately).

When the handle safety block (14, 15) is installed, lift the lever (15) and rotate the handle (fig. 6-7).

A lock can also be installed on the handle to protect the system against tampering (fig. 8).

Seal can be adjusted using the extractable insert on the handle (fig. 3-4).

The seals can be adjusted later with the valve installed on the pipe by simply tightening the union nuts. This "micro adjustment", only possible with FIP valves thanks to the patented "Seat stop system", allows the seal to be recovered where PTFE ball seats are worn due to a high number of manoeuvres.

The Easytorque kit can also be used for micro adjustments (fig. 5).

WARNINGS

- If volatile liquid such as Hydrogen Peroxide (H₂O₂) or Sodium Hypochlorite (NaClO) are used, for safety reasons we recommend you contact the service centre. These liquids, upon vaporising, could create hazardous over pressures in the area between the body and ball.
- Always avoid sudden closing operations and protect the valve from accidental operations.

Fig. 5



Fig. 6



Fig. 7



Fig. 8

