



VKD DN 65÷100
PVDF

DUAL BLOCK® 2-way ball valve

VKD DN 65÷100

FIP has developed a VKD DUAL BLOCK® ball valve to introduce a high reference standard in thermoplastic valve design. VKD is a True Union ball valve that meets the most stringent needs required by industrial applications. This valve is also equipped with a customising Labelling System.



2-WAY DUAL BLOCK® BALL VALVE

- Connection system for weld and flanged joints
- Patented **SEAT STOP®** ball seat carrier system that lets you micro-adjust ball seats and minimise axial force effects
- Easy radial disassembly allowing quick replacement of O-rings and ball seats without any need for tools
- **PN16 True Union valve body** made for PVDF injection moulding equipped with built-in bores for actuation. ISO 9393 compliant test requisites
- Option of disassembling downstream pipes with the valve in the closed position
- **Full bore ball** with high surface finish
- **Integrated bracket** for valve anchoring
- Possibility of installing a gear box or pneumatic and/or electric actuators by applying an ISO standard bore PP-GR flange
- **STAINLESS steel co-moulded stem**, with square section as per ISO 5211

Technical specifications

Construction	2-way True Union ball valve with locked carrier and union nuts.
Size range	DN 65 ÷ 100
Nominal pressure	PN 16 with water at 20° C
Temperature range	-40 °C ÷ 140 °C
Coupling standards	Welding: EN ISO 10931. Can be coupled to pipes according to EN ISO 10931 Flanging system: ISO 7005-1, EN ISO 10931, EN 558-1, DIN 2501, ANSI B.16.5 cl. 150
Reference standards	Construction criteria: EN ISO 16135, EN ISO 10931, Test methods and requirements: ISO 9393 Installation criteria: DVS 2201-1, DVS 2207-15, DVS 2208-1 Actuator couplings: ISO 5211
Valve material	PVDF
Seal material	FPM (standard size O-Ring, EPDM on request); PTFE (ball seats)
Control options	Manual control; electric actuator; pneumatic actuator

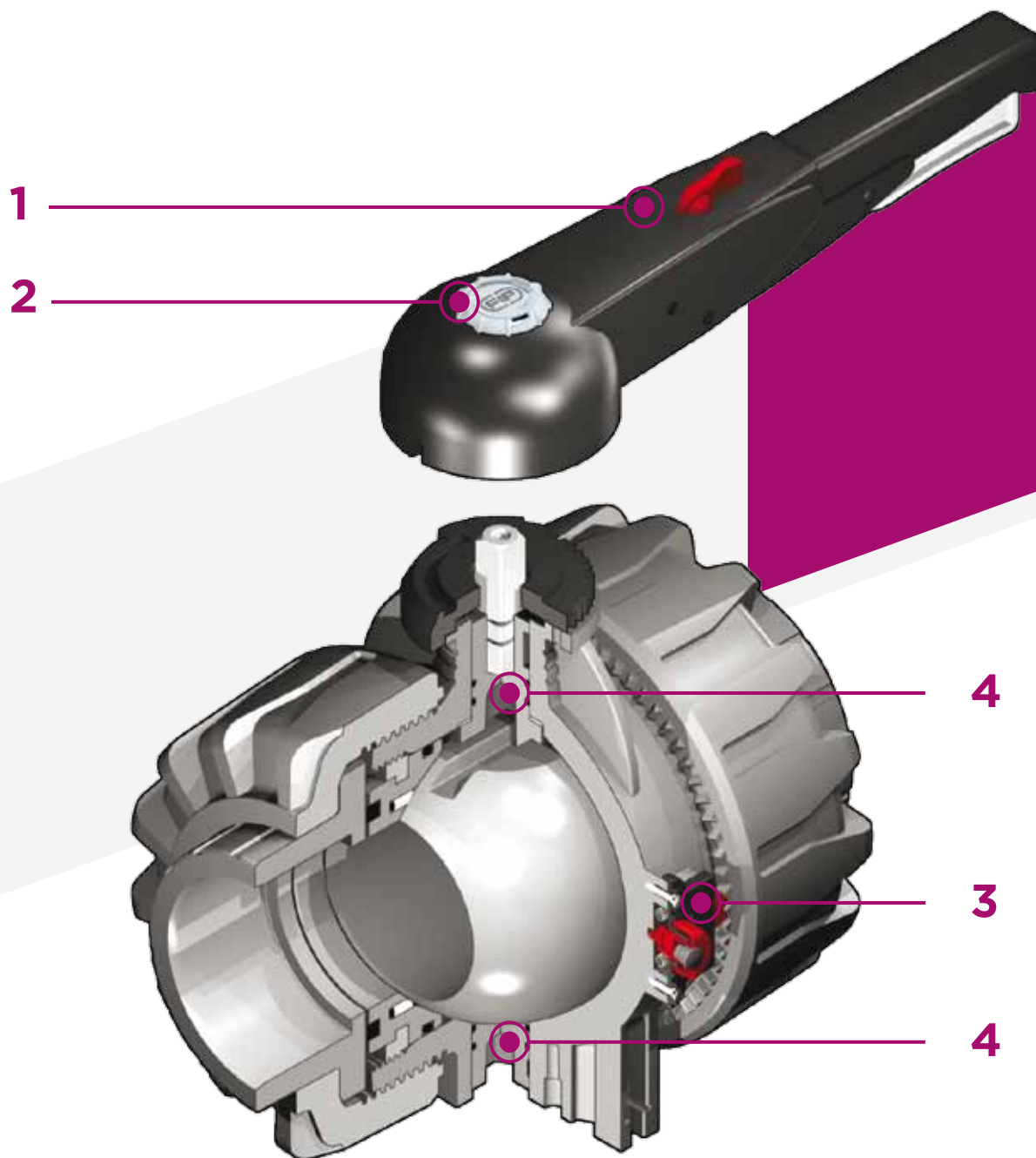

1 HIPVC ergonomic multifunctional handle for quick operation, **lock and graduated adjustment in 10 positions.** Possibility of inhibiting rotation with a lock

2 Customisable Labelling System: built-in LCE module made of a transparent protection plug and **customisable tag holder** using the LSE set (available as an accessory). The customisation lets you identify the valve on the system according to specific needs

3 **DUAL BLOCK®** patented lock system that ensures union nut tightening hold even in severe conditions such as vibrations or heat dilation

4 **Double stem** with double O-Rings for ball centring and operating torque reduction

TECHNICAL DATA

PRESSURE VARIATION ACCORDING TO TEMPERATURE

For water and non-hazardous fluids with regard to which the material is classified as CHEMICALLY RESISTANT. In other cases, a reduction of the nominal pressure PN is required (25 years with safety factor).

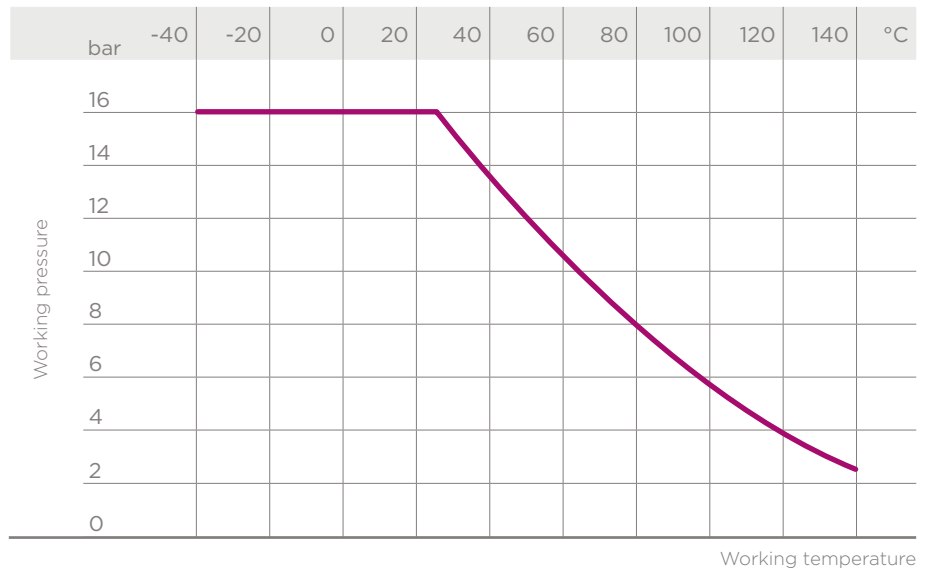

PRESSURE DROP GRAPH

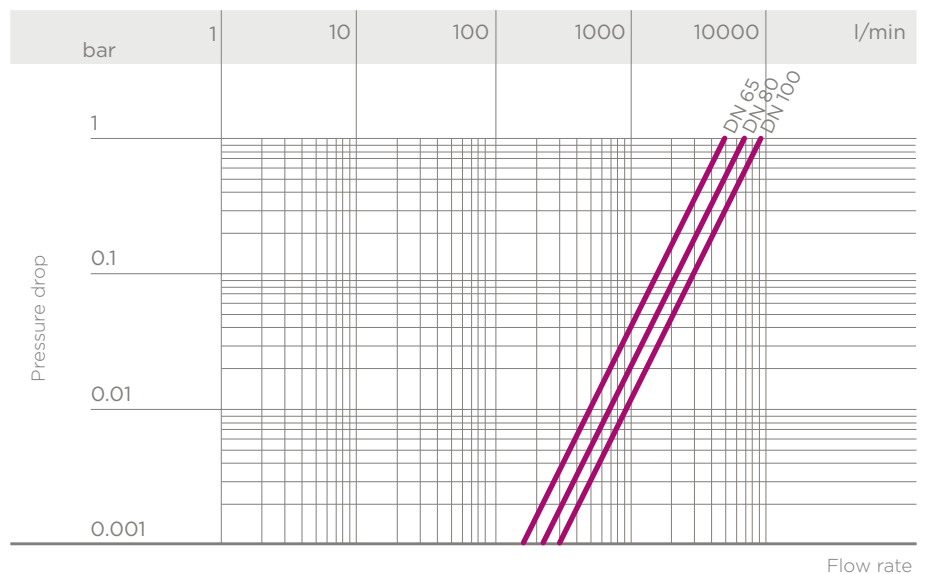

K_v100 FLOW COEFFICIENT

The K_v100 flow coefficient is the Q flow rate of litres per minute of water at a temperature of 20°C that will generate $\Delta p = 1$ bar pressure drop at a certain valve position.

The K_v100 values shown in the table are calculated with the valve completely open.

DN	65	80	100
K _v 100 l/min	5250	7100	9500

DIMENSIONS

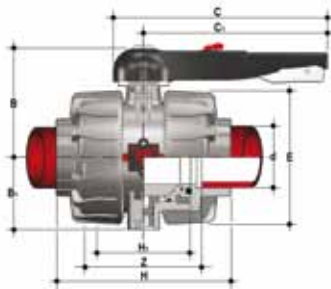

VKDIF

DUAL BLOCK® 2-way ball valve with female ends for socket welding, metric series

d	DN	PN	B	B ₁	C	C ₁	E	H	H ₁	Z	g	Code
75	65	16	164	87	225	175	162	213	133	153	4380	VKDIF075F
90	80	16	177	105	327	272	202	239	149	173	7200	VKDIF090F
110	100	16	195	129	385	330	236	268	167	199	11141	VKDIF110F

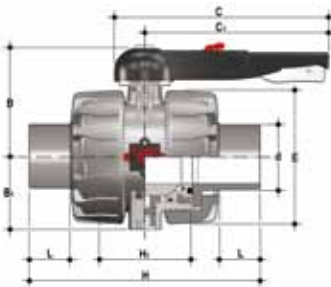

VKDDF

DUAL BLOCK® 2-way ball valve with male ends for socket welding, metric series

d	DN	PN	B	B ₁	C	C ₁	E	H	H ₁	L	g	Code
75	65	16	164	87	225	175	162	284	133	44	4420	VKDDF075F
90	80	16	177	105	327	272	202	300	149	51	6930	VKDDF090F
110	100	16	195	129	385	330	236	340	167	61	10950	VKDDF110F

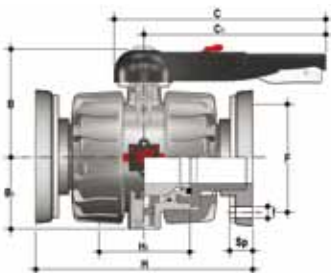

VKDOF

DUAL BLOCK® 2-way ball valve with fixed flanges, drilled EN/ISO/DIN PN10/16.
Face to face according to EN 558-1

d	DN	PN	B	B ₁	C	C ₁	F	f	H	H ₁	U	Sp	g	Code
75	65	16	164	87	225	175	145	17	290	133	4	21	8588	VKDOF075F
90	80	16	177	105	327	272	160	17	310	149	8	21.5	12122	VKDOF090F
110	100	16	195	129	385	330	180	17	350	167	8	21.5	17949	VKDOF110F

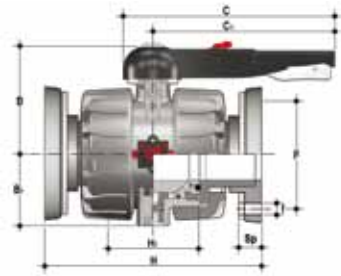

VKDOAF

DUAL BLOCK® 2-way ball valve with fixed flanges, drilled ANSI B16.5 cl.150 #FF. Face to face according to EN 558-1

d	DN	PN	B	B ₁	C	C ₁	F	f	H	H ₁	U	Sp	g	Code
2"1/2	65	16	164	87	225	175	139.7	18	290	133	4	21	8588	VKDOAF075F
3"	80	16	177	105	327	272	152.4	18	310	149	8	21.5	12122	VKDOAF090F
4"	100	16	195	129	385	330	190.5	18	350	167	8	21.5	17949	VKDOAF110F

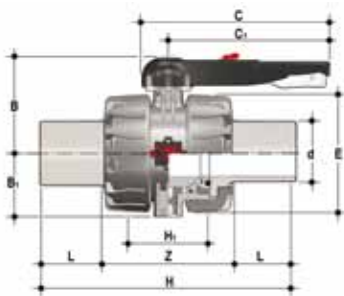

VKDBF

DUAL BLOCK® 2-way ball valve with long spigot male ends in PVDF SDR 21 for butt welding/IR (CVDF)

d	DN	PN	B	B ₁	C	C ₁	E	H	H ₁	L	Z	g	Code
75	65	16	164	87	225	175	162	284	133	71	142	4700	VKDBF075F
90	80	16	177	105	327	272	202	300	149	88	124	7150	VKDBF090F
110	100	16	195	129	385	330	236	340	167	92	156	11300	VKDBF110F

ACCESSORIES

CVDF

End connector in PVDF SDR 21 PN 16, long spigot, for butt welding

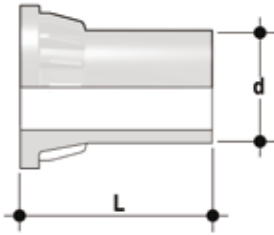

d	DN	PN	L	SDR	Code
75	65	16	110.5	21	CVDF21075
90	80	16	118.5	21	CVDF21090
110	100	16	130.5	21	CVDF21110

LSE

Customisation and label printing set for Easyfit handle made up of precut adhesive sheets and software for guided label creation



d	DN	Code
75	65	LSE040
90	80	LSE040
110	100	LSE040

VKD-MS

The MS kit lets you install a limit switch box with electromechanical or inductive micro switches on a manual VKD valve to remotely signal the valve position (open-closed). The kit can be assembled on the valve even if already installed on the system.

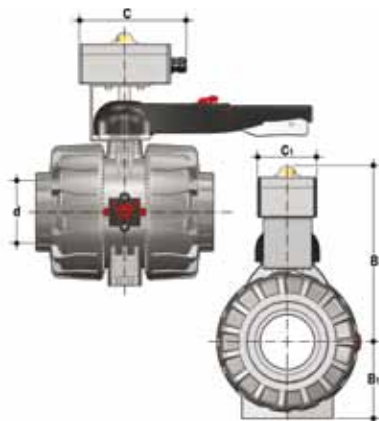

d	DN	B	B ₁	C	C ₁	Protection rate	Code electromechanical	Code inductive	Code Namur
75	65	266	87	150	80	IP67	FKMS1M	FKMS1I	FKMS1N
90	80	279	105	150	80	IP67	FKMS1M	FKMS1I	FKMS1N
110	100	297	129	150	80	IP67	FKMS1M	FKMS1I	FKMS1N

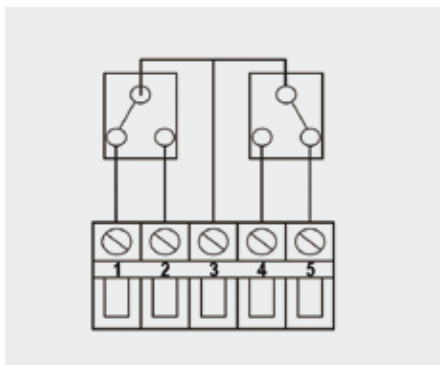

Electromechanical

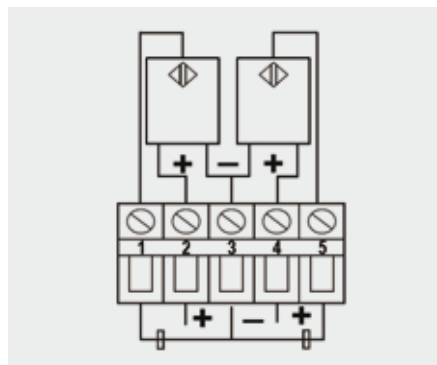

Inductive

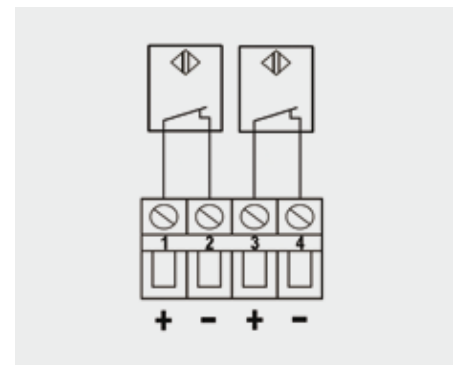

Namur*

* To be used with an amplifier

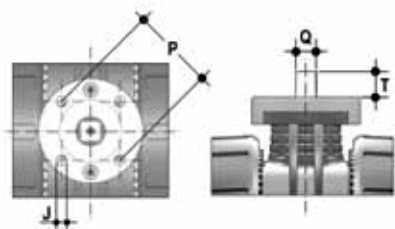

ACTUATOR MOUNTING FLANGE

The valve can be equipped with standard pneumatic or electric actuators and gearbox for heavy-duty operations, using a flange in PP-GR reproducing the drilling pattern provided for by standard ISO 5211 F07

d	DN	P x J	T	Q
75	65	F07 x 9	16	14
90	80	F07 x 9	16	14
110	100	F07 x 9	19	17

FASTENING AND SUPPORTING



All valves, whether manual or actuated, must be adequately supported in many applications.

The VKD valve series is therefore provided with an integrated bracket that permits direct anchoring of the valve body without the need of other components.

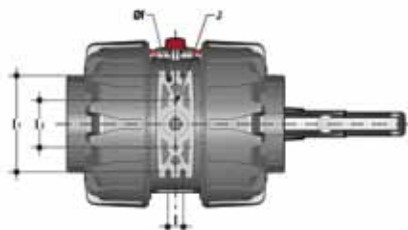

d	DN	J	f	l	l ₁	l ₂
75	65	M6	6.3	17.4	90	51.8
90	80	M6	8.4	21.2	112.6	63
110	100	M8	8.4	21.2	137	67

CUSTOMISATION

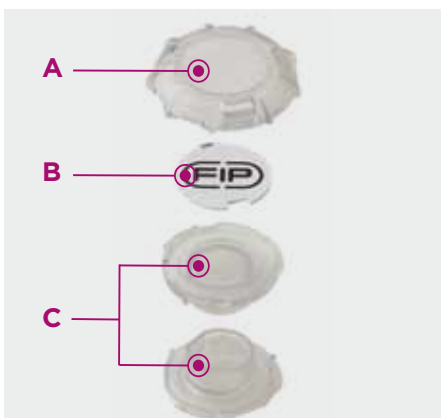

The VKD DN 65÷100 valve is equipped with the customisable Labelling System.

This system lets you create special labels to insert in the handle. This makes it extremely easy to apply company logos, identification serial numbers or service indications such as, for example, the valve function in the system, the transported fluid, but also specific information for customer service, such as the customer name or installation date or location on the valves.

The specific LCE module is a standard supply and is made up of a rigid transparent water-resistant PVC plug (A-C) and white tag holder (B) made of the same material, bearing on the FIP logo one side.

The plate, inserted in the plug, can be removed and, once overturned, used for customisation by applying labels printed with the software supplied with the LSE set.

Proceed as follows to apply the label on the valve:

- 1) Remove the upper part of the transparent plug (A) rotating it counter-clockwise as indicated by the "Open" label on the plug and remove it.
- 2) Extract the tag holder from its housing on the lower part of the plug (C)
- 3) Apply the adhesive label on the tag holder (B) to align the profiles matching the tab position.
- 4) Reinsert the tag holder in its housing at the bottom of the plug
- 5) Reposition the top of the plug in the housing rotating it clockwise; this way the label is protected against the elements.

COMPONENTS

EXPLODED VIEW

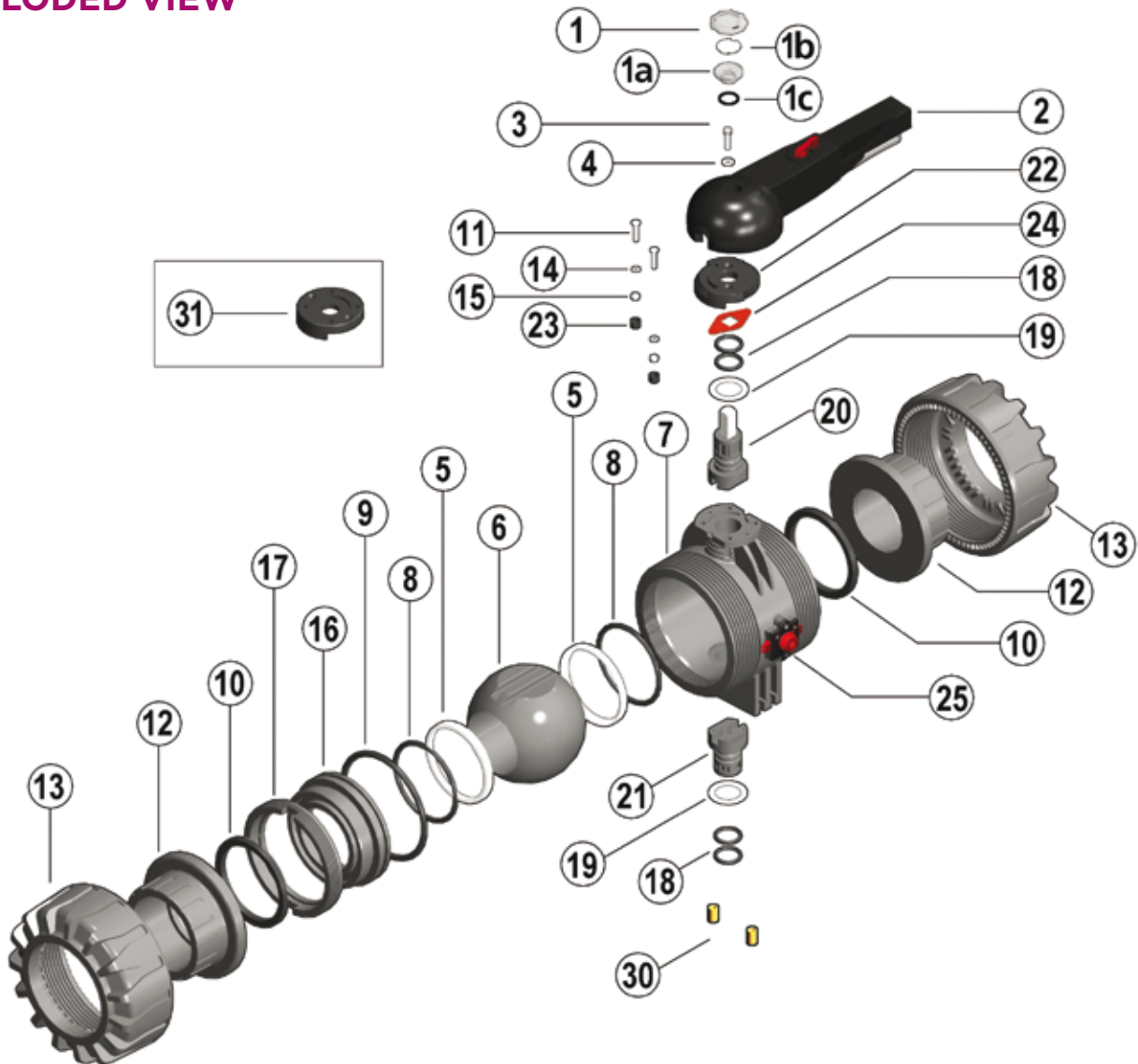

1-1a · Transparent protection plug (PVC - 1)

1b · Tag holder (PVC - 1)

1c · O-Ring (NBR - 1)

2 · Handle (HIPVC - 1)

3 · Screw (Stainless steel - 1)

4 · Stop washer (STAINLESS steel - 1)

5 · Ball seat (PTFE - 2)*

6 · Ball (PVDF - 1)*

7 · Body (PVDF - 1)

8 · Ball seat O-ring (FPM - 2)*

9 · Radial seal O-Ring (FPM - 1)*

10 · Socket seal O-Ring (FPM - 2)*

11 · Screw (Stainless steel - 2)

12 · End connector (PVDF - 2)*

13 · Union nut (PVDF - 2)*

14 · Stop washer (Stainless steel - 2)

15 · Nut (Stainless steel - 2)

16 · Ball seat carrier (PVDF - 1)

17 · Threaded ring (PVDF - 1)

18 · Stem O-Ring (FPM - 4)*

19 · Anti-friction disk (PTFE - 2)*

20 · Upper stem (PVDF/STAINLESS steel - 1)

21 · Loser stem (PVDF - 1)

22 · Plate (PP-GR - 1)

23 · Protection plug (PE - 2)

24 · Position indicator (PA - 1)

25 · DUAL BLOCK® (PP-GR + various - 1)

30 · Threaded insert (Brass - 2)**

31 · Actuation plate (PP-GR - 1)**

* Spare parts

** Accessories

The material of the component and the quantity supplied are indicated between brackets

DISASSEMBLY

- 1) Isolate the valve from the line (release the pressure and empty the pipeline).
- 2) Release the union nuts by rotating the button (25) to the left, pointing the arrow on the open lock (fig. 1).
- 3) Unscrew the union nuts (13) and extract the body (7) (fig. 2).
- 4) Before dismounting, hold the valve in a vertical position and open it 45° to drain any liquid that might remain.
- 5) Open the valve.
- 6) Remove the protection plug on the handle (2) and unscrew the screw (3) with the washer (4).
- 7) Remove the handle (2).
- 8) Remove the screws (11) and plate (22) from the body (7).
- 9) Insert the two supplied wrench protrusions in the corresponding apertures on the threaded ring (17), extracting it by rotating counter-clockwise with the ball seat carrier (16) (fig. 3).
- 10) Press on the ball (6), being careful not to scratch it, and remove it from the body.
- 11) Press the upper stem (20) inwards and extract it from the body and remove the lower stem (21). Remove the anti-friction disks (19).
- 12) Remove the O-Ring (8, 9, 10, 18) and PTFE ball seats (5) extracting them from their grooves, as illustrated in the exploded view.

ASSEMBLY

- 1) All the O-rings (8, 9, 10, 18) must be inserted in their grooves as shown in the exploded view.
- 2) Place the anti-friction disks (19) on the stems (20-21) and insert the stems in their housings in the body.
- 3) Place the PTFE ball seats (5) in the housings in the body (7) and in the ball seat carrier (16).
- 4) Insert the ball (6) rotating it to the closed position.
- 5) Insert the carrier with threaded ring (17) into the body and tighten up in the clockwise direction using the supplied tool, to limit stop.
- 6) Position the plate (22) with rack on the body, and screw in the screws (11) washers (14) and nuts (15).
- 7) The handle (2) with protection plug (1, 1a, 1b, 1c) should be placed on the stem (20) (fig. 4).
- 8) Screw in the screw (3) with the washer (4) and position the protection plug (1, 1a, 1b, 1c).
- 9) Insert the valve between the end connectors (12) and tighten the union nuts (13), making sure that the socket seal O-rings (10) do not exit their seats.
- 10) Release the union nuts by rotating the button (25) to the right, pointing the arrow on the closed lock (fig. 1).



Note: during assembly operations, it is advisable to lubricate the rubber seals. Mineral oils are not recommended for this task as they react aggressively with EPDM rubber.

INSTALLATION

Before proceeding with installation, please follow these instructions carefully:

- 1) Check that the pipes to be connected to the valve are aligned in order to avoid mechanical stress on the threaded joints.
- 2) Make sure the DUAL BLOCK® union nut lock system (25) is in the FREE position.
- 3) Unscrew the union nuts (13) and insert them on the pipe segments.
- 4) Solvent weld or screw the end connectors (12) onto the pipe ends.
- 5) Position the valve body between the end connectors and fully tighten the union nuts (13) clockwise with an appropriate wrench.
- 6) Lock the union nuts rotating the button (25) clockwise (see paragraph "union nut lock").
- 7) If necessary, support the pipework with FIP pipe clips or by means of the carrier built into the valve itself (see paragraph "fastening and supporting").

Adjust the ball seat carriers using the supplied tool (fig. 3).

The seals can be adjusted later with the valve installed on the pipe by simply tightening the union nuts. This "micro adjustment", only possible with FIP valves thanks to the patented "Seat stop system", allows the seal to be recovered where PTFE ball seats are worn due to a high number of manoeuvres.

Fig. 1



Fig. 2



Fig. 3



Fig. 4



UNION NUT LOCK



Rotate the button to the left, pointing the arrow on the open lock to unlock DUAL BLOCK®: the valve union nuts are free to rotate clockwise and counter-clockwise. Rotate the button to the right, pointing the arrow on the closed lock to lock DUAL BLOCK®: the valve union nuts are blocked in the desired position.

HANDLE LOCK



Thanks to the multifunctional handle and the red manoeuvre button on the lever, you can perform a 0°-90° operation and a graduated operation by means of the 10 intermediate positions and a stop lock: the handle can be locked in each of the 10 positions by simply pressing the Free-lock button. A lock can also be installed on the handle to protect the system against tampering.

The valve is two-way and can be installed in any position. It can also be installed at end line or tank.

WARNINGS

- If volatile liquid such as Hydrogen Peroxide (H₂O₂) or Sodium Hypochlorite (NaClO) are used, for safety reasons we recommend you contact the service centre. These liquids, upon vaporising, could create hazardous over pressures in the area between the body and ball.
- Always avoid sudden closing operations and protect the valve from accidental operations.