

## UNI-DIRECTIONAL KNIFE GATE VALVE MU SERIES



KGV MU SERIES SEMI LUGGED WITH ELASTOMERIC SLEEVE & HANDWHEEL RS



KGV MU SERIES SEMI LUGGED WITH PROFILE SEAT & HANDWHEEL NRS



KGV MU SERIES FULLY LUGGED WITH PROFILE SEAT & HANDWHEEL RS

The MU series knife gate is a uni-directional wafer valve, soft or metal-metal seated, designed to handle pulp, arid and powder mediums, mainly used in industrial bulk and silo outlet applications. Sleeve (DN50-DN300) and packing material can be replaced without valve disassembly from the pipeline.

### GENERAL FEATURES

- Monoblock one-piece body: semi lugged (wafer) and optionally, fully lug-between flanges and fully lug-end
- Adjustable stuffing box, allowing packing material replacement without valve disassembly from the line
- Two sealing systems:
  - **DN50-DN300:** sleeve (tight version) or metallic ring (metal-metal valve). Same valve can be used for both options. Sleeve can be replaced by only holding the valve on one bolt and rotating 90°.
  - Warning:* sleeve seated valves designed only for flanges DN2632.
  - **DN350-DN600:** profile o-ring (tight version). Metal-metal seated valve without elastomeric parts on the passage. Profile o-ring cannot be replaced without valve disassembly from the pipeline.
- Short face-to-face dimension
- Easy drive replacement
- Proximity and limit switch mounting points







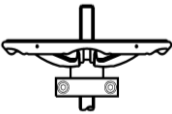

### APPLICATION FIELDS

- Pulp and paper
- Bulk handling
- Mining
- Chemical process
- Slaughterhouse
- Food and beverage
- Exhaust-gas
- Etc

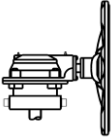
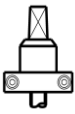
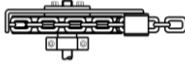
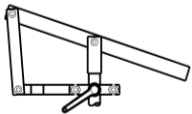
### TECHNICAL DATA

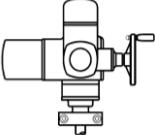
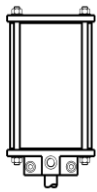
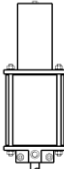
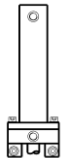
- **Size range:**  
DN-50 (2") to DN-600 (24")
- **Working pressure:**  
DN 50 to DN 200: 10 kg/cm<sup>2</sup>  
DN 250 to DN 300: 7 kg/cm<sup>2</sup>  
DN 350 to DN 400: 6 kg/cm<sup>2</sup>  
DN 450 to DN 600: 4 kg/cm<sup>2</sup>
- **Flange ratings:**  
PN10, PN16 and ANSI B16.5 (class 150)  
Note: other flange drillings under request
- **Face to face dimension:**  
According to K1 DIN3202 up to DN-300  
From DN-350 to DN-600 CYL standard
- **Coating:**  
RAL 5017, 150 microns epoxy coated
- **Directives:**  
Pressure equipment directive 97/23/CE  
DIR 2006/42/CE (MACHINES)

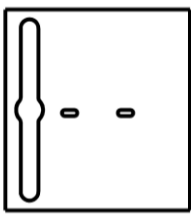
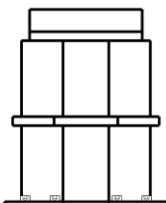
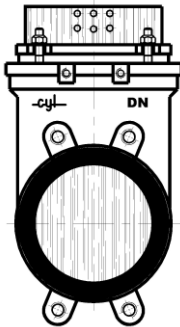
ASSEMBLY CONFIGURATION

<b>OPERATION</b>	 <p>Rising stem handwheel</p>	 <p>Non rising stem handwheel</p>	 <p>Gearbox</p>	 <p>Key Cap</p>	 <p>Chain Wheel</p>	 <p>Quick closing</p>
	 <p>Rising stem coupling A</p>	 <p>Non rising stem coupling B-3</p>	 <p>Electric actuator</p>	 <p>Double acting pneumatic actuator</p>	 <p>Spring-return pneumatic actuator</p>	 <p>Oil hydraulic actuator</p>
<b>PLATES</b>	 <p>Plates</p>		 <p>Hand protections for automated valves</p>		 <p>Tight closed bonnet rising stem</p>	
	 <p>Semi lugged (wafer) DN50-DN300</p>		 <p>Semi lugged (wafer) DN350-DN600</p>			
	<p><b>ACCESSORIES</b></p> <ul style="list-style-type: none"> <li>- Revolving handle</li> <li>- Locking device</li> <li>- Overriding actuator</li> <li>- Limit stroke</li> <li>- Flush holes</li> <li>- Mechanical limit switches</li> <li>- Proximity limit switches</li> <li>- Mechanical position indicator</li> <li>- V-port (Aisi 316)</li> <li>- Deflector cone (Ni-hard)</li> <li>- Chest scraper (Bronze / PPS plastic)</li> <li>- Solenoid valve</li> <li>- Extension, headstock rising stem / non rising stem</li> <li>- Enlarged plates</li> <li>- Rubber horse</li> </ul>					

## MATERIAL SPECIFICATION & PART LIST

### MU-SERIES FROM DN50 TO DN300

No.	DESCRIPTION	MATERIAL
1	Sleeve	NBR (standard) EPDM, PTFE, VITON, POLIURETHANE (optional)
2	Gate	SS 316 (standard) SS316L, SS316TI, DUPLEX2205, SMO254 (optional)
3	Body	Cast iron - GJL250 (standard) GJS400, CF8M, DUPLEX 2205, SMO254 (optional)
4	Screws & nuts	A-4
5	Packing material	PTFE+NBR (standard) PTFE+EPDM, ARAMIDE, GRAPHITE (optional)
6	Packing gland	Ductile iron - GJS400 (standard) CF8M, DUPLEX 2205, SMO 254 (optional)
7	Plates	1.0580 (standard) SS 316 (optional)
-	Stem	SS 316
-	Bearing	1.0401 (standard) SS 316 (optional)
-	Handwheel	1.0037
-	Pneumatic act.	Aluminium
-	Hand-protections	1.0580 (standard) SS 316 (optional)

Figure 1. Exploded view of KGV MU series semi lugged with **sleeve (tight seat)**

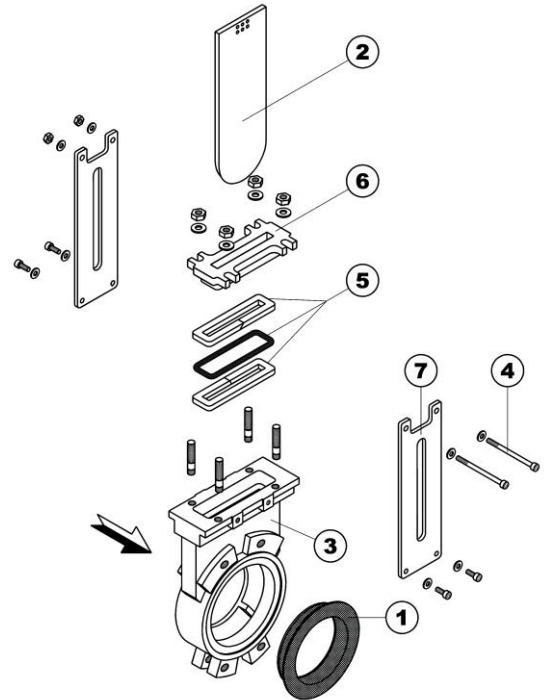

No.	DESCRIPTION	MATERIAL
1.1	Metallic ring	1.041 (standard) SS 316 (optional)
2	Gate	SS 316 (standard) SS316L, SS316TI, DUPLEX2205, SMO254 (optional)
3	Body	Cast iron - GJL250 (standard) GJS400, CF8M, DUPLEX 2205, SMO 254 (optional)
4	Screws & nuts	A-4
5	Packing material	PTFE+NBR (standard) PTFE+EPDM, ARAMIDE, GRAPHITE (optional)
6	Packing gland	Ductile iron - GJS400 (standard) CF8M, DUPLEX 2205, SMO 254 (optional)
7	Plates	1.0580 (standard) SS 316 (optional)
-	Stem	SS 316
-	Bearing	1.0401 (standard) SS 316 (optional)
-	Handwheel	1.0037
-	Pneumatic act.	Aluminium
-	Hand-protections	1.0580 (standard) SS 316 (optional)

Figure 2. Exploded view of KGV MU-SERIES semi lugged with **metallic ring (metal-metal seat)**

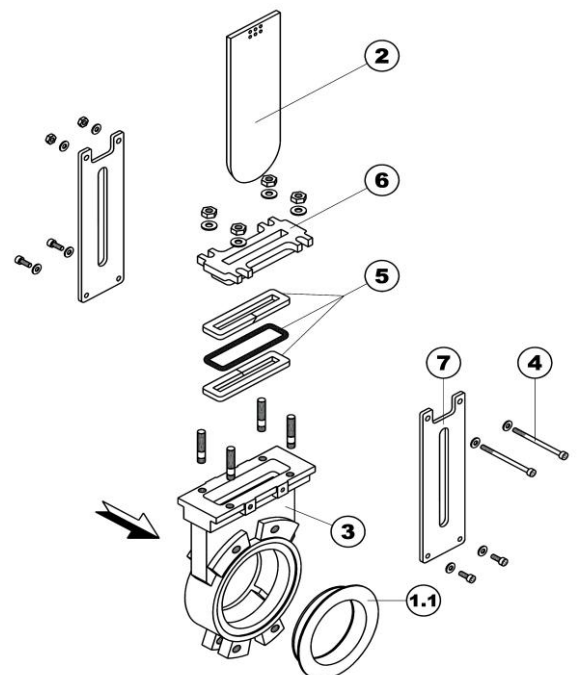

## MU-SERIES FROM DN350 TO DN600

No.	DESCRIPTION	MATERIAL
1	Profile o-ring	NBR (standard) EPDM, PTFE, VITON, POLIURETHANE (optional)
1.1	Fastening ring	SS 316
2	Gate	SS 316 (standard) SS316L,SS316TI,DUPLEX2205,SMO254(optional)
3	Body	Cast iron - GJL250 (standard) GJS400, CF8M, DUPLEX2205, SMO254 (optional)
4	Screws & nuts	A-4
5	Packing material	PTFE+NBR (standard) PTFE+EPDM, ARAMIDE, GRAPHITE (optional)
6	Packing gland	Ductile iron - GJS400 (standard) CF8M, DUPLEX 2205, SMO 254 (optional)
7	Plates	1.0580 (standard) SS 316 (optional)
-	Stem	SS 316
-	Bearing	1.0401 (standard) SS 316 (optional)
-	Handwheel	1.0037
-	Pneumatic act.	Aluminium
-	Hand-protections	1.0580 (standard) SS 316 (optional)

Figure 3. Exploded view of KGV MU series semi lugged with **profile o-ring (tight seat)**

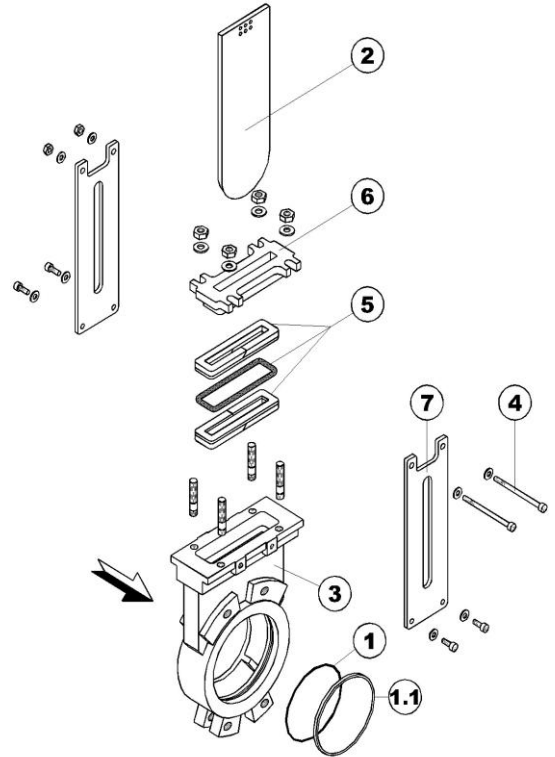

No.	DESCRIPTION	MATERIAL
2	Gate	SS 316 (standard) SS316L,SS316TI,DUPLEX2205,SMO254(optional)
3	Body	Cast iron - GJL250 (standard) GJS400, CF8M, DUPLEX2205, SMO254 (optional)
4	Screws & nuts	A-4
5	Packing material	PTFE+NBR (standard) PTFE+EPDM, ARAMIDE, GRAPHITE (optional)
6	Packing gland	Ductile iron - GJS400 (standard) CF8M, DUPLEX 2205, SMO 254 (optional)
7	Plates	1.0580 (standard) SS 316 (optional)
-	Stem	SS 316
-	Bearing	1.0401 (standard) SS 316 (optional)
-	Handwheel	1.0037
-	Pneumatic act.	Aluminium
-	Hand-protections	1.0580 (standard) SS 316 (optional)
-	Metal-Metal seat	Cast iron/Ductile iron (standard) AISI 316 (optional)

Figure 4. Exploded view of KGV MU series semi lugged with **metal-metal seat**

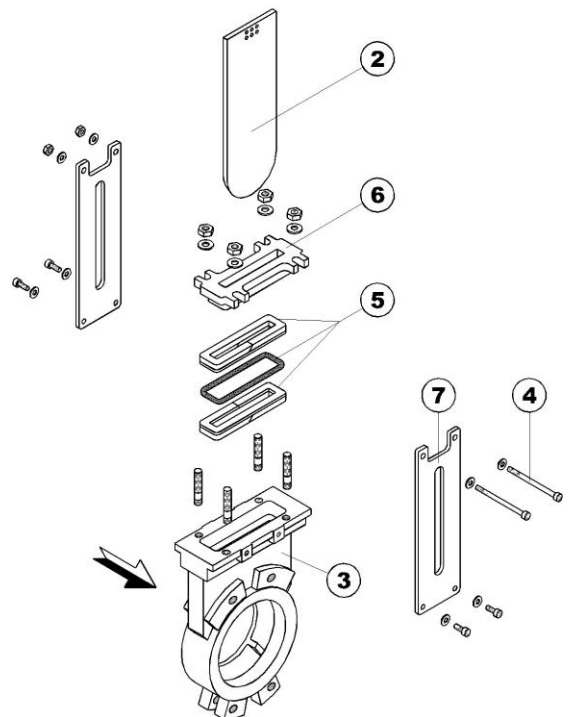

**APPLICATION AND TEMPERATURE RANGE**

<b>SEAT MATERIALS</b>			
<b>Material</b>	<b>Min. temperature (°C)</b>	<b>Max. temperature (°C)</b>	<b>APPLICATIONS</b>
<b>NBR</b>	-30	+80	Hydrocarbons and biogas waste
<b>EPDM</b>	-30	+90	Clean and chlorided water
<b>VITON</b>	-40	+180	Organic acids, hydrocarbons and heat resistant
<b>PTFE</b>	-10	+200	Heat, friction, acids, chemical and corrosion resistant
<b>POLIURETHANE</b>	-10	+80	Abrasive mediums/mineral handling
<b>WHITE SILICONE</b>	-20	+180	Food industry (FDA conformity)
<b>METAL-METAL</b>	-30	+400	Solids, abrasive/high temperature mediums

*\*More details and other sealing materials under request.*

<b>PACKING MATERIALS</b>			
<b>Material</b>	<b>Min. temperature (°C)</b>	<b>Max. temperature (°C)</b>	<b>APPLICATIONS</b>
<b>COTTON-PTFE</b>	-30	+100	Hydrocarbons
<b>PURE PTFE</b>	-10	+200	Heat, friction, acids, chemical and corrosion resistant
<b>ARAMIDE</b>	-40	+250	Bulk handling
<b>GRAPHITE</b>	-40	+300	Hydrocarbons, heat resistant and solids
<b>SPECIAL PACKING FOR HIGH TEMPERATURE</b>	-10	+1000	High temperature

*\*More details and other sealing materials under request.*

## DIMENSIONAL DRAWINGS

### MU-SERIES FROM DN50 TO DN300

Figure 5. KGV MU series semi lugged rising stem & handwheel

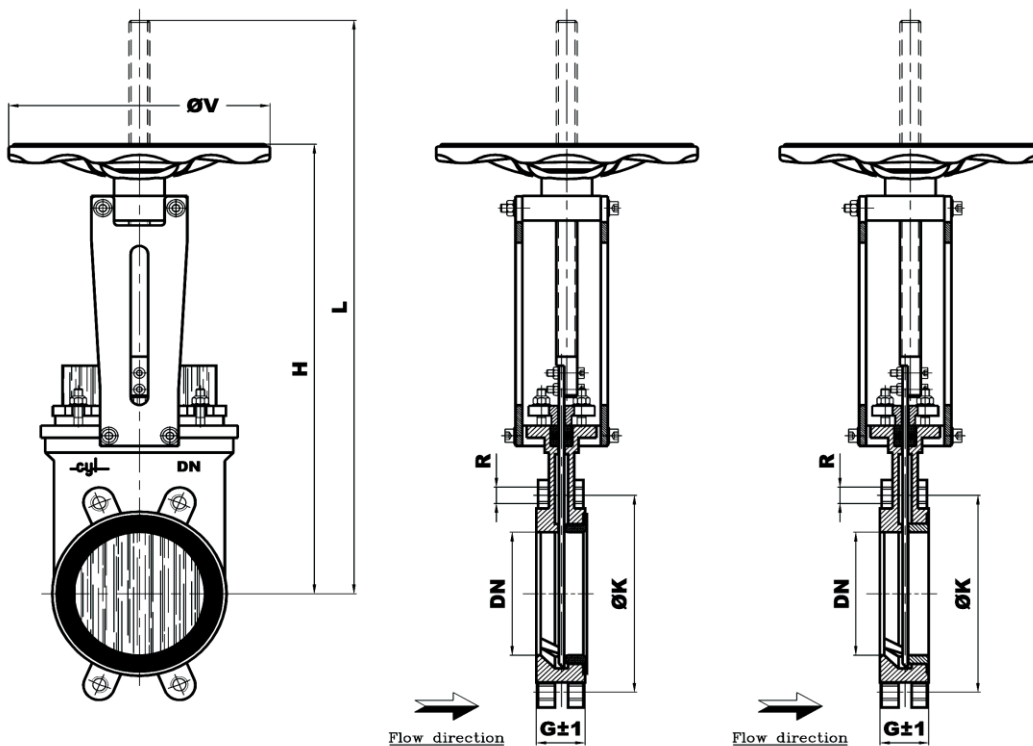

**Tight elastomeric-seat**

**Steel ring-seat  
Metal/metal seat**

Figure 6. KGV MU series semi lugged rising stem with d/a pneumatic actuator

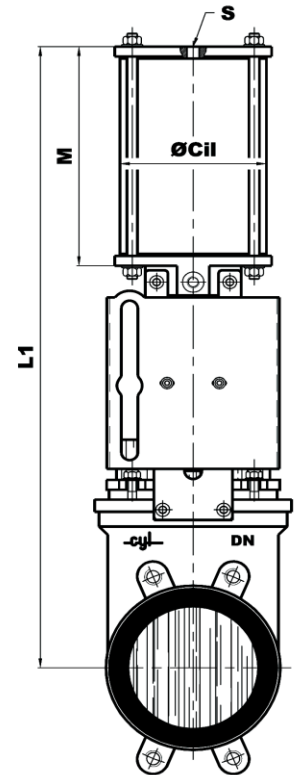

DN	G±1	H	L	ØV	L1	M	S	Ø Cil	Min. Torque (Nm)	Max. Torque (Nm)	Spindle thread
50	43	306	366	175	406	147	1/4 " G	80	8	16	Tr18x4i
65	43	336	411	175	448	160	1/4 " G	80	10	17	Tr18x4i
80	46	366	448	225	490	177	1/4 " G	100	12	19	Tr20x4i
100	52	393	495	225	537	197	1/4 " G	100	15	22	Tr20x4i
125	56	446	573	225	625	232	3/8 " G	125	17	24	Tr20x4i
150	56	548	699	300	757	267	3/8 " G	160	25	50	Tr24x5i
200	60	659	860	300	928	327	1/2 " G	190	27	53	Tr24x5i
250	68	733	984	300	1050	375	1/2 " G	190	50	69	Tr24x5i
300	78	870	1172	400	1229	428	1/2 " G	190	63	84	Tr28x5i

\* Data sheet for ØK & ØD stated in "flange drillings chapter".

## MU-SERIES FROM DN350 TO DN600

Figure 7. KGV MU series semi lugged rising stem & handwheel

Figure 8. KGV MU series semi lugged rising stem with handwheel & gearbox

Figure 9. KGV MU series semi lugged with d/a pneumatic actuator

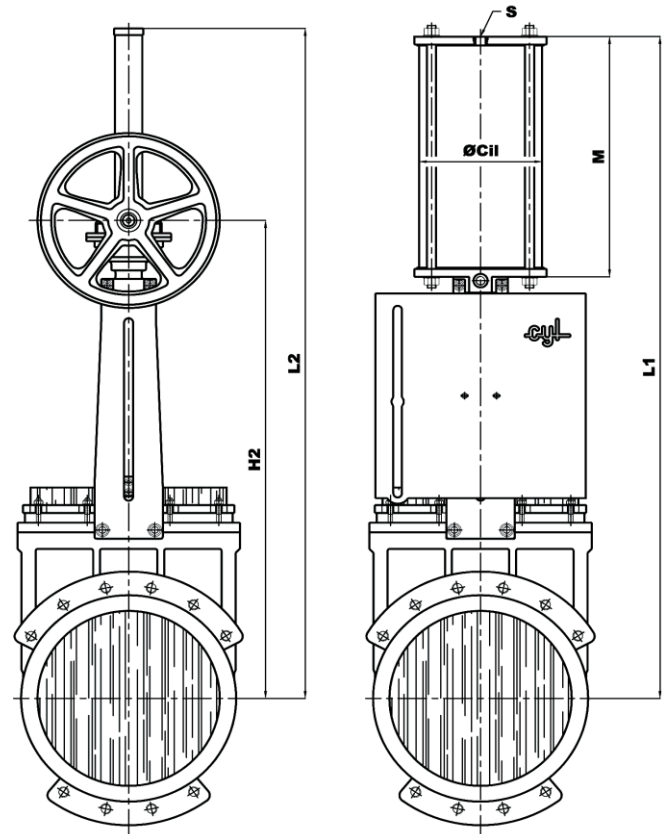
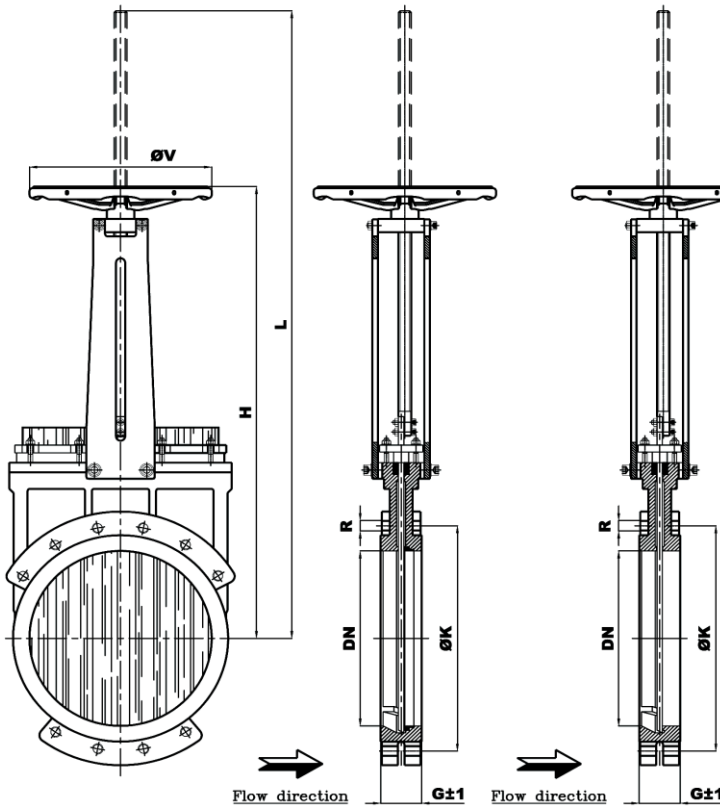

Tight profile o-ring

Metal-metal seat

DN	G±1	H	L	ØV	L2	H2	L1	M	Ø Ci1	S	Min. Torque (Nm)	Max. Torque (Nm)	Spindle thread
350	96	915	1267	400	1364	975	1345	499	250	1/2 " G	78	102	Tr28x5i
400	100	1033	1435	400	1532	1093	1513	549	250	1/2 " G	90	110	Tr28x5i
450	106	1131	1579	500	1649	1146	1653	601	300	1/2 " G	215	259	Tr40x7i
500	110	1235	1743	500	1793	1240	1802	656	300	1/2 " G	223	320	Tr40x7i
600	110	1437	2045	500	2098	1445	2108	757	300	1/2 " G	249	388	Tr40x7i

\* Data sheet for ØK & ØD stated in "flange drillings chapter".

FLANGE DRILLINGS

**FLANGE DRILLING - PN10**

DN 50-65

DN 80-200

DN 250-300

DN 350-400

DN 450-600

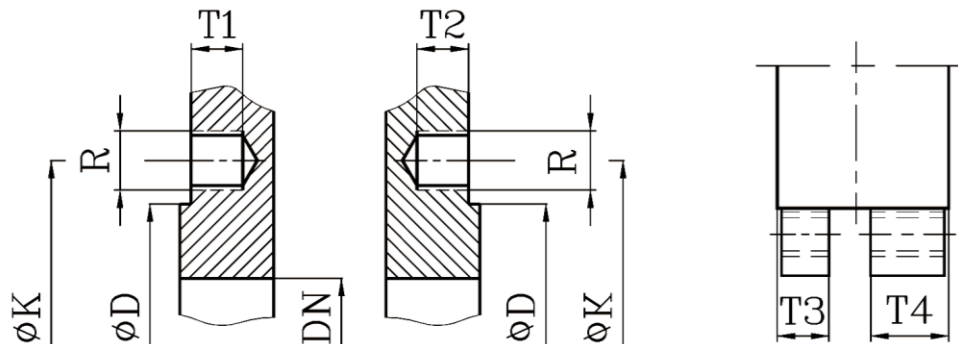
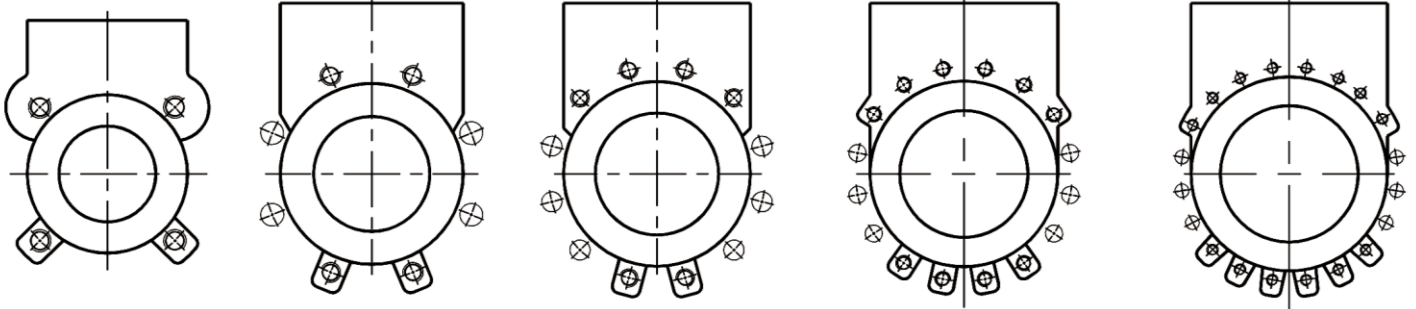

**Bolting Arrangements PN-10 Knife Gate Valve**

DN	K	D	N (1)	N (2)	N (3)	T1	T2	T3	T4	R
50	125	95	4	-	4	9	10	37		M-16
65	145	105	4	-	4	10	10	38		M-16
80	160	135	4	4	8	7	9	16	19	M-16
100	180	158	4	4	8	7	11	17	23	M-16
125	210	188	4	4	8	7	17	15	27	M-16
150	240	212	4	4	8	11	12	20	22	M-20
200	295	268	4	4	8	13	15	21	24	M-20
250	350	320	6	6	12	13	16	28	29	M-20
300	400	370	6	6	12	16	23	29	38	M-20
350	460	410	10	6	16	21	21	24	24	M-20
400	515	465	10	6	16	21	21	26	26	M-24
450	565	520	14	6	20	22	22	26	26	M-24
500	620	566	14	6	20	22	22	28	28	M-24
600	725	672	14	6	20	22	22	28	28	M-27

N (1)- Nº of tapped holes    N (2)- Nº of through holes    N (3)- Nº of flange holes



**FLANGE DRILLING - PN16**

DN 50–65

DN 80–150

DN 200–300

DN 350–400

DN 450–600

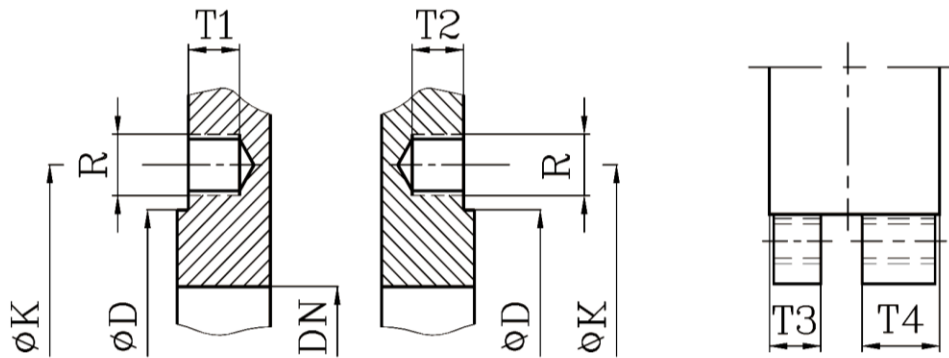
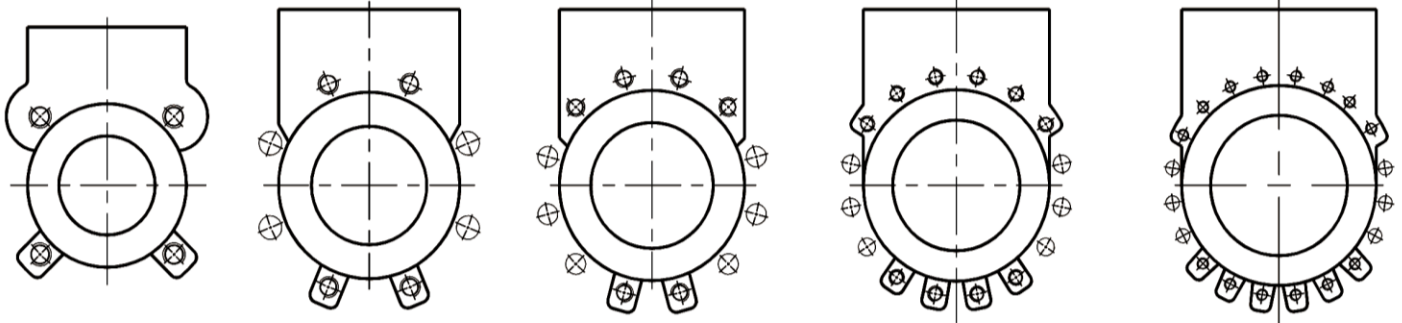

**Bolting Arrangements PN-16 Knife Gate Valve**

DN	K	D	N (1)	N (2)	N (3)	T1	T2	T3	T4	R
50	125	95	4	-	4	9	10	37		M-16
65	145	105	4	-	4	10	10	38		M-16
80	160	135	4	4	8	7	9	16	19	M-16
100	180	158	4	4	8	7	11	17	23	M-16
125	210	188	4	4	8	7	17	15	27	M-16
150	240	212	4	4	8	11	12	20	22	M-20
200	295	268	6	6	12	13	15	21	24	M-20
250	355	320	6	6	12	13	16	28	29	M-24
300	410	370	6	6	12	16	23	29	38	M-24
350	470	410	10	6	16	21	21	24	24	M-24
400	525	465	10	6	16	21	21	26	26	M-27
450	585	520	14	6	20	22	22	26	26	M-27
500	650	566	14	6	20	22	22	28	28	M-30
600	770	672	14	6	20	22	22	28	28	M-33

N (1)- Nº of tapped holes    N (2)- Nº of through holes    N (3)- Nº of flange holes

**FLANGE DRILLING - ASA 150**

DN 50–80

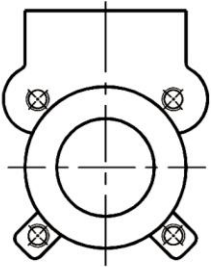

DN 100–200

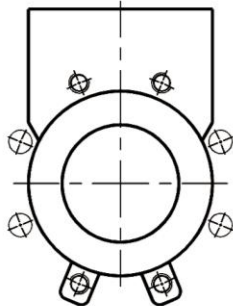

DN 250–300

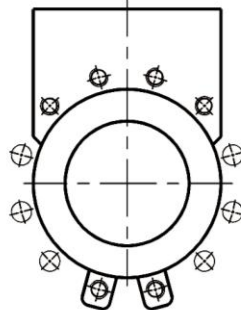

DN 350

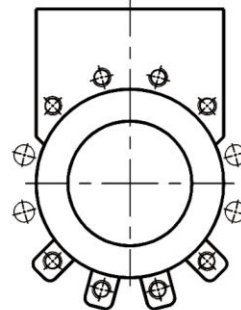

DN 400–450

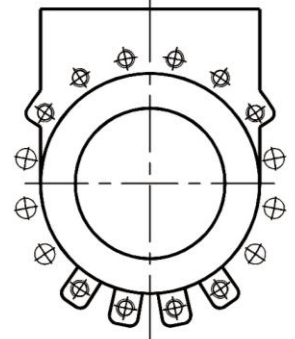

DN 500–600

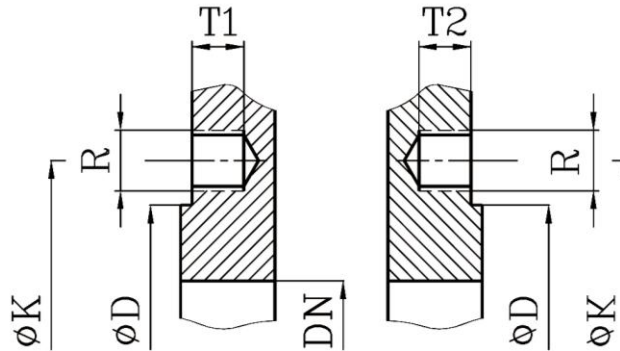
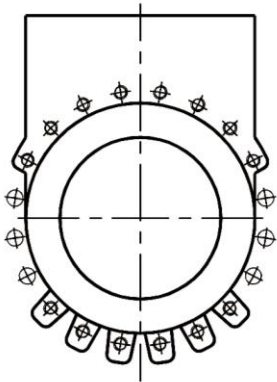

**Bolting Arrangements ASA-150 Knife Gate Valve**

DN	K	D	N (1)	N (2)	N (3)	T1	T2	T3	T4	R
50	120,6	95	4	-	4	9	10	37		5/8 "
65	139,7	105	4	-	4	10	10	38		5/8 "
80	152,4	135	4	4	8	7	9	16	19	5/8 "
100	190,5	158	4	4	8	7	11	17	23	5/8 "
125	215,9	188	4	4	8	7	17	15	27	3/4 "
150	241,3	212	4	4	8	11	12	20	22	3/4 "
200	298,4	268	4	4	8	13	15	21	24	3/4 "
250	361,9	320	6	6	12	13	16	28	29	7/8 "
300	431,8	370	6	6	12	16	23	29	38	7/8 "
350	476,2	410	8	4	12	21	21	24	24	1 "
400	539,7	465	10	6	16	21	21	26	26	1 "
450	577,8	520	10	6	16	22	22	26	26	1 1/8 "
500	635	566	14	6	20	22	22	28	28	1 1/8 "
600	749,3	672	14	6	20	22	22	28	28	1 1/8 "

N (1)- Nº of tapped holes    N (2)- Nº of through holes    N (3)- Nº of flange holes



## ORDERING GUIDE

SERIES	OPERATIONS	BODY MATERIAL	DN	SEAT MATERIAL	BODY TYPE	FLANGE DRILLING
Example: MU-SERIES	V	11		NI	W	PN-10
	V → Handwheel r.s	11 → Cast iron		NI → NBR	W → Semi lugged (WAFER)	PN-10
	VR → Handwheel r.s + Bevel Gearbox	12 → Ductile iron		EP → EPDM		PN-16
	F → Handwheel n.r.s.	14 → Stainless steel		VI → VITON		ASA 150
	FR → Handwheel n.r.s. + Bevel Gearbox	17 → Fully stainless steel		TE → PTFE		
	C → Key cap n.r.s	18 → Carbon steel		PU → POLIURETHANE		
	CR → Key cap + Spur Gearbox			MET → METAL-METAL		
	B → Iso top flange r.s.					
	BR → Iso top flange r.s. + Bevel Gearbox					
	FB → Iso top flange n.r.s.					
	FBR → Iso top flange n.r.s. + Bevel Gearbox					
	M → Electric actuator r.s.					
	MR → Electric actuator r.s. + Bevel Gearbox					



SERIES	OPERATIONS	MATERIAL	DN	SEAT	BODY TYPE	FLANGE
	FM → Electric actuator n.r.s	11 → Cast iron		NI → NBR	W → Semi lugged (WAFER)	PN-10
	FMR → Electric actuator n.r.s + Bevel Gearbox	12 → Ductile iron		EP → EPDM		PN-16
	P → Quick closing lever	14 → Stainless steel		VI → VITON		ASA-150
	N → D/A pneumatic actuator	17 → Fully stainless steel		TE → PTFE		
	SE → S/A pneumatic actuator	18 → Carbon steel		PU → POLIURETHANE		
	H → Oil hydraulic actuator			MET → METAL-METAL		
	VCH → Chain wheel r.s.					
	VCHR → Chain wheel r.s. + Bevel Gearbox					
	FCH → Chain wheel n.r.s.					
	FCHR → Chain wheel n.r.s. + Bevel Gearbox					