

Description

Swing check valve, for mounting directly between flanges according to DIN. Maintenance not required. For liquids and gases in the industrial range, general services, water treatment. Not suitable for media with solid components.

Product features

- Max. working pressure DN 32-250 → 16 bar, DN 300-600 → 10 bar
- Rating PN 10, PN 16, other ratings on request



The check valves RHEA R1C meet the safety requirements of the pressure Equipments Directive 2014/68/EU (PED) appendix 1 for fluids of the groups 1 and 2.

Construction

1	Body	9	Jig
2	Disc	10	Plate
3	Screw	11	Jig for pin
4	Eye bolt	12	Screws
5	O-Ring (seat)	13	Pin for spring
6	O-Ring (flange)	14	Spring right (option, max. DN 300)
7	Spring (option)	15	Spring left (option, max. DN 300)
8	Pivot		

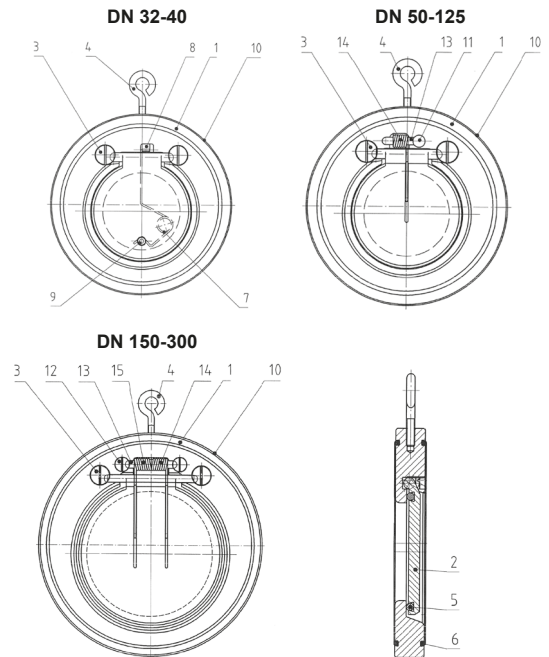

Hydraulic characteristics

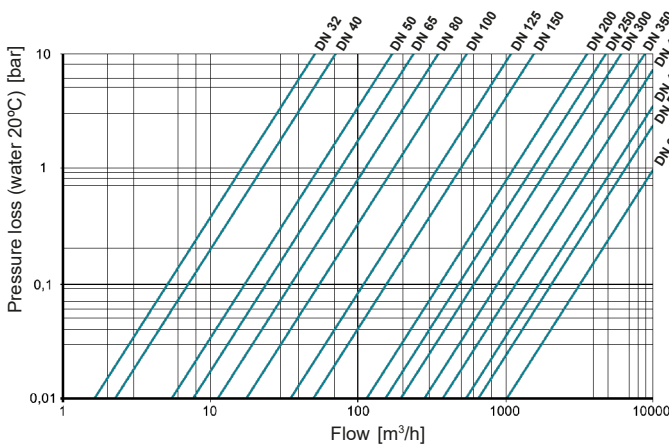

DN [mm]	kv [m³/h]	Opening pressure [mbar]			
		without spring	with spring	without spring	with spring
32	16,2	~ 2	~ 15	~ 10	~ 25
40	22,2	~ 2	~ 15	~ 10	~ 25
50	54	~ 2	~ 15	~ 10	~ 25
65	75	~ 2	~ 15	~ 10	~ 25
80	112	~ 2	~ 15	~ 10	~ 25
100	172	~ 2	~ 15	~ 10	~ 25
125	342	~ 2	~ 15	~ 10	~ 25
150	490	~ 2	~ 15	~ 10	~ 25
200	1128	~ 4	~ 17	~ 14	~ 25
250	1500	~ 4	~ 17	~ 14	~ 25
300	2290	~ 4	~ 17	~ 14	~ 25
350	2890	~ 6		~ 18	
400	3700	~ 6		~ 18	
450	5000	~ 6		~ 18	
500	6550	~ 6		~ 24	
600	9500	~ 6		~ 26	

Dimensions

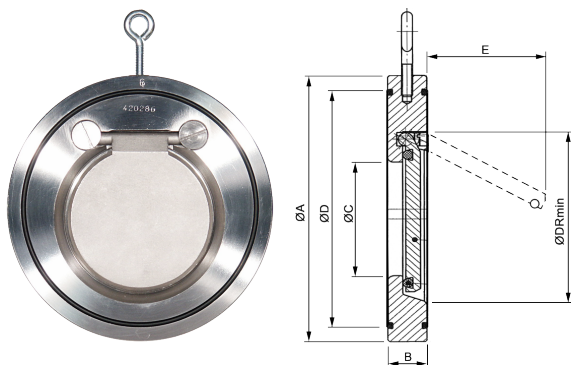

DN	A (PN 10)	A (PN 16)	B	C	D	E	DR	[kg]
32	85	85	15	18	59	22	37	0,5
40	95	95	16	22	72	25	43	0,8
50	109	109	14	32	86	37	54	0,9
65	129	129	14	40	109	50	70	1,2
80	144	144	14	54	119	61	82	1,5
100	164	164	18	70	146	77	106	2,4
125	195	195	18	92	173	98	131	3,4
150	220	220	20	112	197	120	159	4,6
200	275	275	22	154	255	160	207	7,5
250	330	331	26	192	312	190	260	13
300	380	386	32	227	363	220	309	21
350	440	446	38	266	416	250	341	33
400	491	499	44	310	467	290	392	47
450	541	558	52	350	520	340	442	71
500	596	621	58	400	550	390	493	89
600	698	738	62	486	660	470	595	109



Type code

R1C	100	.	3	3	-	3GZ	.	4C0	.	N	-	(S)
①	②		③	④		⑤		⑥		⑦		⑧

① Type	R1C	Swing check valve - wafer type	DN 32-600
② Nominal diameter	032-600	mm	
③ Working pressure	2	10 bar	DN 300-600
	3	16 bar	DN 32-250
④ Rating	2	PN 10	DN 300-600
	3	PN 16	DN 32-250
	A	ANSI cl. 150	DN 32-600
	Other standards on request (PN 6/25/40, ANSI B16.5 Cl.300)		
⑤ Body	3GZ	Galvanized steel 1.0460	
	4C0	Stainless steel 1.4408 (~AISI 316)	
	5C0	Aluminiumbronze ASTM B148 C95800 / G-Cu Al 10 Ni	
⑥ Disc	3HZ	Galvanized steel 1.0619	DN 32-100
	3GZ	Galvanized steel 1.0460	DN 125-600
	4C0	Stainless steel 1.4408 (~AISI 316)	
	4W0	Super Duplex 1.4469	
⑦ O-Ring	N	Nitrile (NBR)	-10°C ÷ 90°C
	E	EPDM	-10°C ÷ 120°C
	V	Viton® (FPM)	-10°C ÷ 150°C
	T	PTFE	-10°C ÷ 200°C
	M	Metal seated (without O-ring)	-10°C ÷ 400°C
⑧ Spring	S	Option: with spring, stainless steel	DN 32-300

Other executions on request !

Operating instructions

Appropriate use in accordance to designed capabilities:

RHEA R1C swing check valves are designed to block media on one side of the pipe within allowable pressure and temperature limits and to be installed in a pipe system only. **They may be used only with media, which the material and the seals are resistant to.** They are not suitable for media with solid components.

Storage:

Swing check valves include sealing elements consisting of organic material, that reacts to environmental effects. Therefore, they are to be stored in their original packaging in a place, which is also to be kept as cool, dry and dark as possible. The front and back sides of the swing check valves must not be mechanically damaged.

Transport:

The personnel must pay special attention, when big swing check valves (>DN 100) are unpacked and transported. The valve is to be held in a horizontal position in a way, that it can open at the top only. This is to avoid, that the valve unintentionally drops down and is damaged.



Installation:

- Possible damages to the swing check valves and O-rings are to be checked prior to installation. Check if the valve can be moved. Damaged parts must not be installed.
- Make sure that only those swing check valves are being installed, that meet the operational requirements regarding pressure category, chemical resistance, connection and dimensions.
- Make sure to install a minimum of 5 x nominal diameter of straight pipeline in front of and behind the swing check valve.
- Do not install the valves directly onto a pump flange.
- Avoid pulsation and pressure impact.
- Vertical throughput is allowable only if the valve can open at the top.
- In case of horizontal throughput, the ring screw must be at the top.
- Watch flow direction (see arrow on the plate) !
- The swing check valves are placed between the flanges by means of a ring screw. They are put in their central position according to the outer diameter of the case and the flange screw inner side.
- Tighten the flange screws crosswise.
- After the installation is finished, check the tightness of the connections by a pressure check.

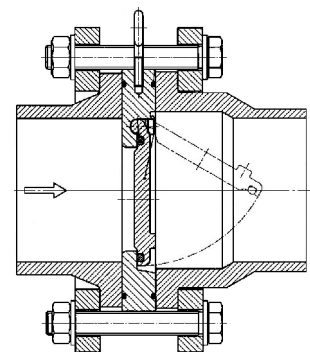

Special risks:

Before the swing check valve is being removed, pressure has to be completely taken off the plant to avoid media escaping from the pipe. Fluid being left in the pipe must be drained off. Fluid, which has remained in the valve and comes out during removal, is to be collected. If hazardous fluids or gases are left in the valves, the safety measurements required must be taken.

The technical data are noncommittal and do not assure you of any properties. Please refer to our general sales conditions. Modifications without notice.

© 2020 InterApp AG, all rights reserved